

M1ST DESIGN
Studio za dizajn interijera

Idejno - izvedbeno rješenje privatnog prostora u Zagrebu
Investitor: Kupac Građanin

M1st design
Dizajner: Matej Kušević
matej.kusevic@m1stdesign.com
+385998218100
m1stdesign.com
svibanj, 2026. godina

TLOCRTI



ID.-IZV. RJEŠENJE
tlocrti

Idejno - izvedbeno rješenje privatnog prostora u Zagrebu
Investitor: Kupac Građanin

M1st design
Dizajner: Matej Kušević
matej.kusevic@m1stdesign.com
+385998218100
m1stdesign.com
svibanj, 2026. godina

IDEJNO - IZVEDBENO RJEŠENJE

iskaz površina

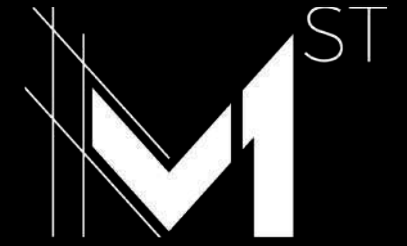
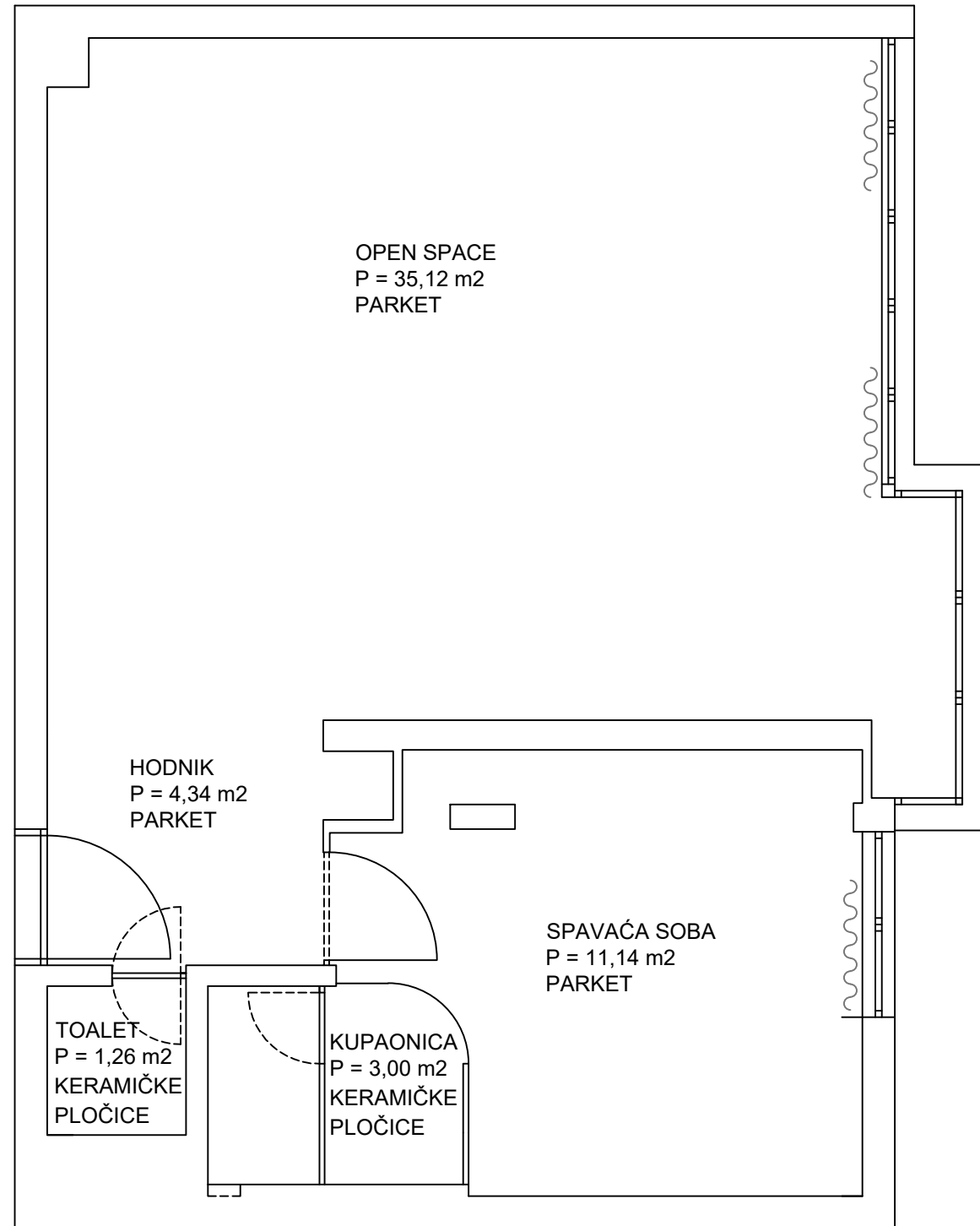
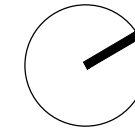

ID.-IZV. RJEŠENJE

iskaz površina

Idejno - izvedbeno rješenje privatnog prostora u Zagrebu
Investitor: Kupac Građanin

M1st design
Dizajner: Matej Kušević
matej.kusevic@m1stdesign.com
+385998218100
m1stdesign.com
svibanj, 2026. godina

IDEJNO - IZVEDBENO RJEŠENJE

tlocrt

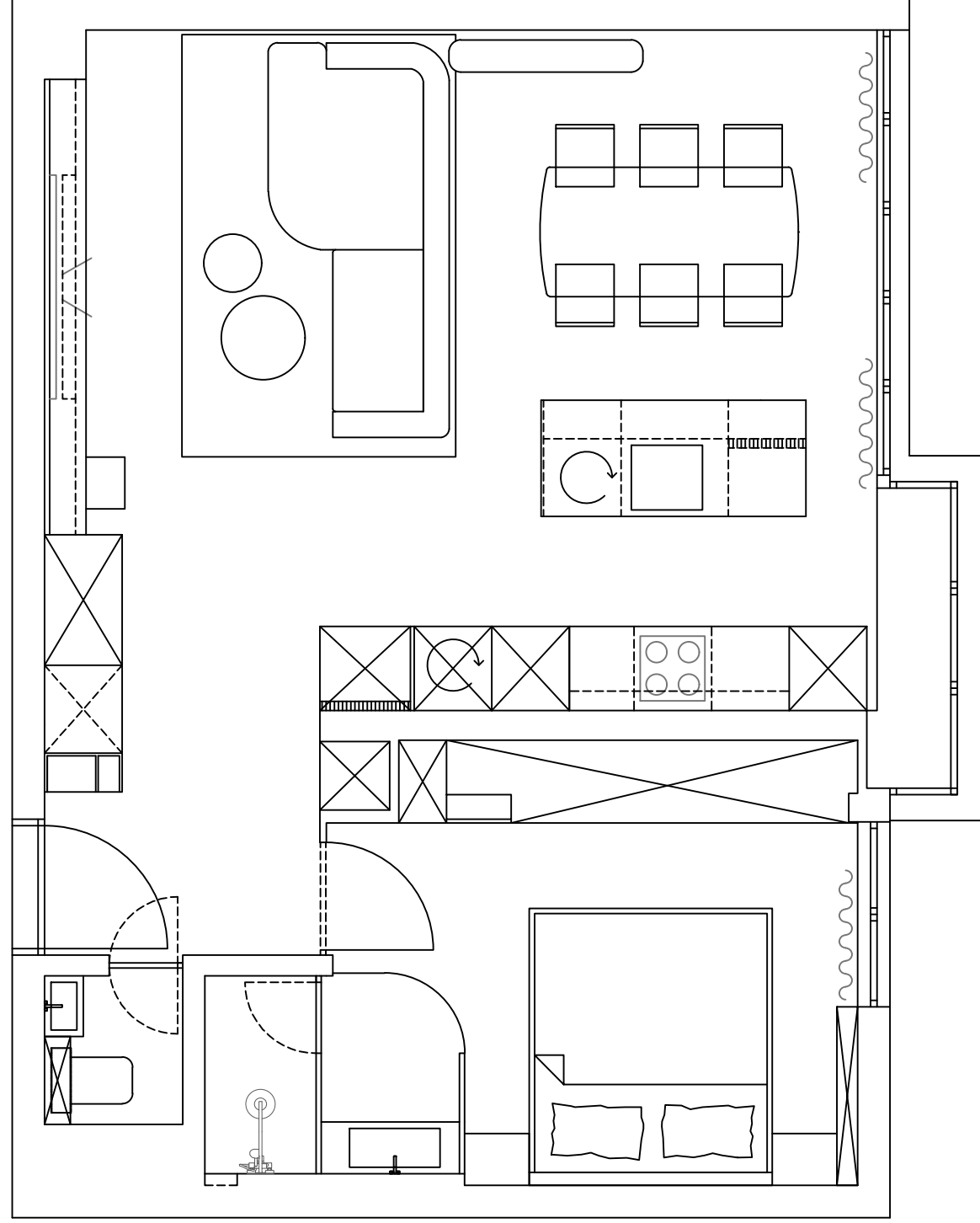
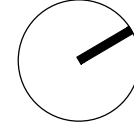

ID.- IZV. RJEŠENJE

Idejno - izvedbeno rješenje privatnog prostora u Zagrebu
Investitor: Kupac Građanin

M1st design
Dizajner: Matej Kušević
matej.kusevic@m1stdesign.com
+385998218100
m1stdesign.com
svibanj, 2026. godina

IDEJNO - IZVEDBENO RJEŠENJE

kotirano

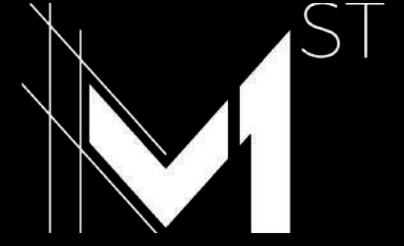
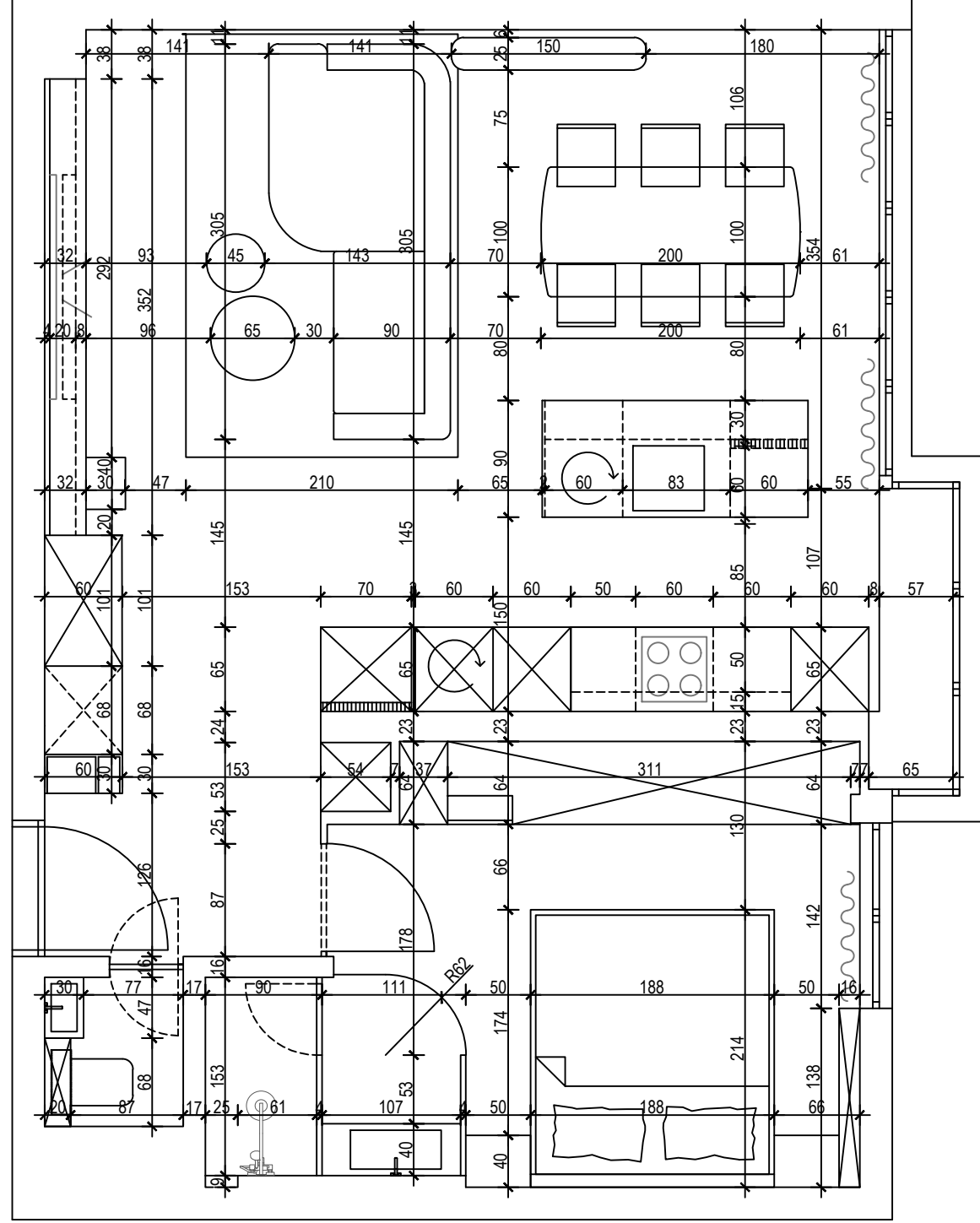
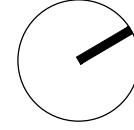

ID.- IZV. RJEŠENJE

Idejno - izvedbeno rješenje privatnog prostora u Zagrebu
Investitor: Kupac Građanin

M1st design
Dizajner: Matej Kušević
m1stdesign.com
+385998218100
m1stdesign.com
svibanj, 2026. godina

IDEJNO - IZVEDBENO RJEŠENJE

opisano

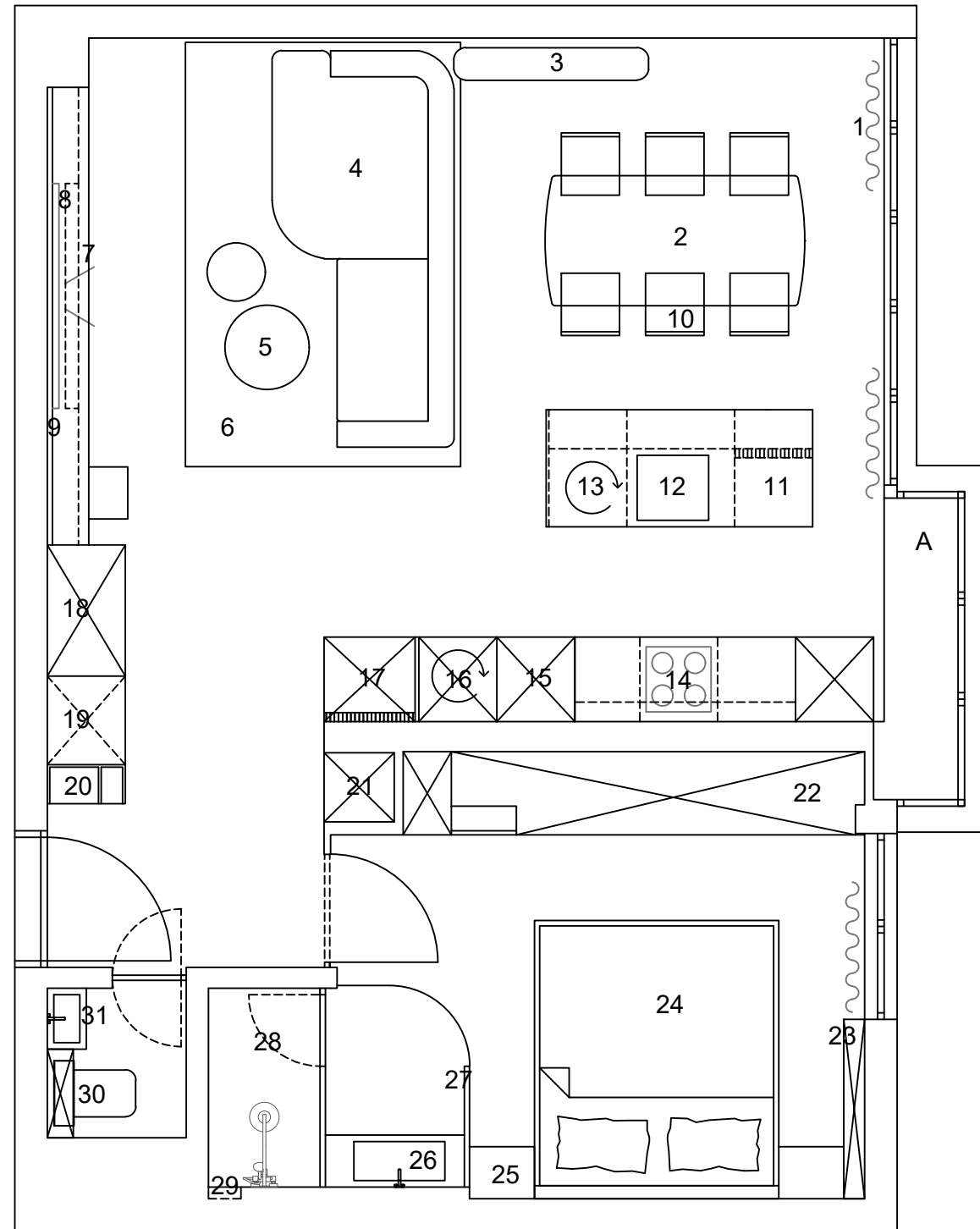
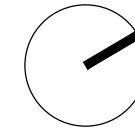

LEGENDA

- 1 ZAVJESE
- 2 STOL + STOLICE
- 3 KONZOLNI STOL
- 4 KUTNA GARNITURA
- 5 STOLIĆ
- 6 TEPIH
- 7 TV KLUPA
- 8 TV
- 9 TV WALL
- 10 POLUBARSKJE STOLICE
- 11 VINSKI HLADNJAK
- 12 SUDOPER
- 13 PERILICA POSUĐA
- 14 INDUKCIJA
- 15 PEĆNICA+MIKROVALNA
- 16 PERILICA/SUŠILICA RUBLJA
- 17 XL HLADNJAK
- 18 ORMAR
- 19 KLUPICA
- 20 KONZOLA
- 21 SKL. ELEMENT
- 22 ORMAR
- 23 PLITKI ELEMENT
- 24 KREKET 180X200
- 25 NOĆNI ORMARIĆ
- 26 KUPAONSKI ELEMENT
- 27 ZID OD STAKLENE OPEKE
- 28 WALK-IN TUŠ
- 29 NIŠA
- 30 WC
- 31 UMIVAONIK

A
Klupica za sjedenje pod prozorom sa skladišnim elementima. Forma istog će se definirati po uklanjanju postojećeg elementa te uvidu na fiksne elemente (jedinice klima uređaja).



ID.- IZV. RJEŠENJE

Idejno - izvedbeno rješenje privatnog prostora u Zagrebu
Investitor: Kupac Građanin

M1st design
Dizajner: Matej Kušević
matej.kusevic@m1stdesign.com
+385998218100
m1stdesign.com
svibanj, 2026. godina

IDEJNO - IZVEDBENO RJEŠENJE

grafička dorada

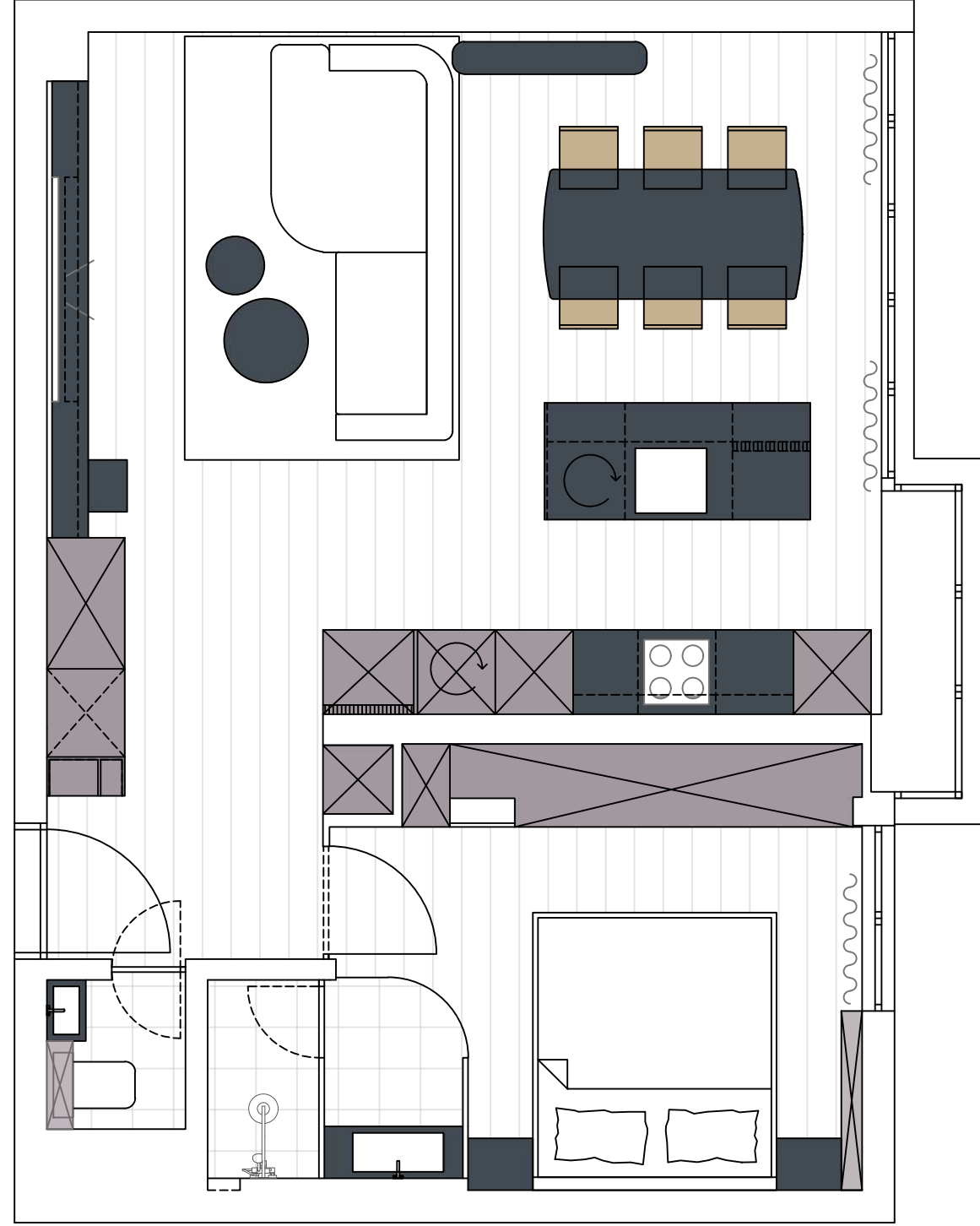
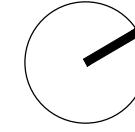

LEGENDA

- ZIDOVI
- SKLADIŠNI PROSTORI
- TEPIH
- SJEDEĆI ELEMENTI
- 'RADNE' PLOHE
- KERAMIKA
- DRVENI PODOVI



ID.- IZV. RJEŠENJE

Idejno - izvedbeno rješenje privatnog prostora u Zagrebu
Investitor: Kupac Građanin

M1st design
Dizajner: Matej Kušević
matej.kusevic@m1stdesign.com
+385998218100
m1stdesign.com
svibanj, 2026. godina

TEHNIČKI NACRTI



ID.- IZV. RJEŠENJE
teh. nacrti

Idejno - izvodbeno rješenje privatnog prostora u Zagrebu
Investitor: Kupac Građanin

M1st design
Dizajner: Matej Kušević
matej.kusevic@m1stdesign.com
+385998218100
m1stdesign.com
svibanj, 2026. godina

IDEJNO - IZVEDBENO RJEŠENJE

teh. nacrti namještaj i zidne obloge



ID.- IZV. RJEŠENJE

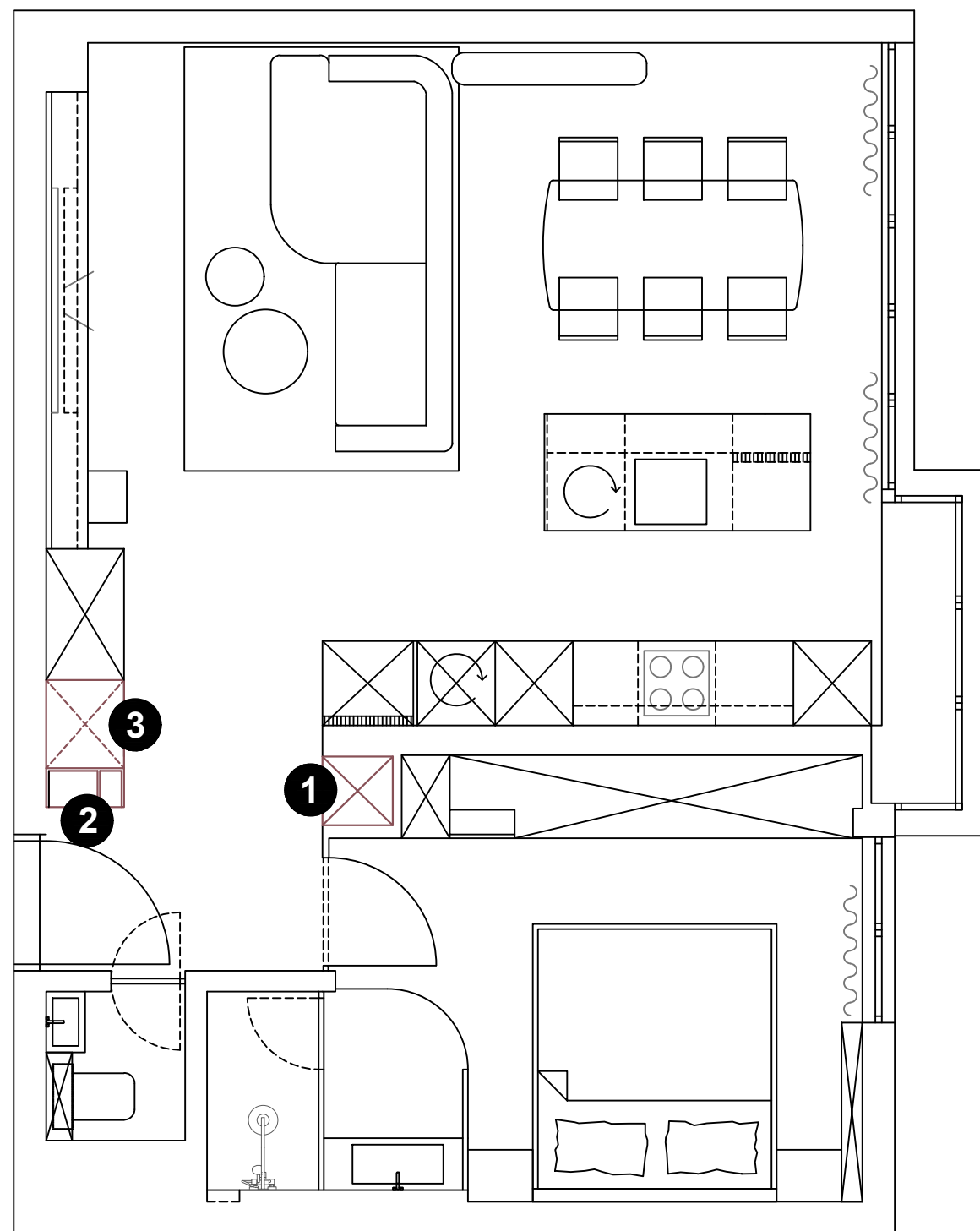

HODNIK

Skladišni element u hodniku je vrlo jednostavan, a zamišljen je kao cipelnik sa klasičnim otvaranjem. Klupica za preobuvanje se s desne strane naslanja na leđa konzole. Posjeduje ladicu koja se otvara na tip-on sistem. Sa stražnje strane se nalazi brončano ogledalo. Konzola se sastoji od otvorenih polica i brončanog ogledala. Osvijetljena je sa 3 LED trake s unutrašnjih bočnih strana polica.

Ugraditi LED rasvjetu 3000K.

MATERIJAL:

Fronte: U707 ST9 Svileni siva
Korpus: U705 ST9 Svileni siva
Brončano ogledalo

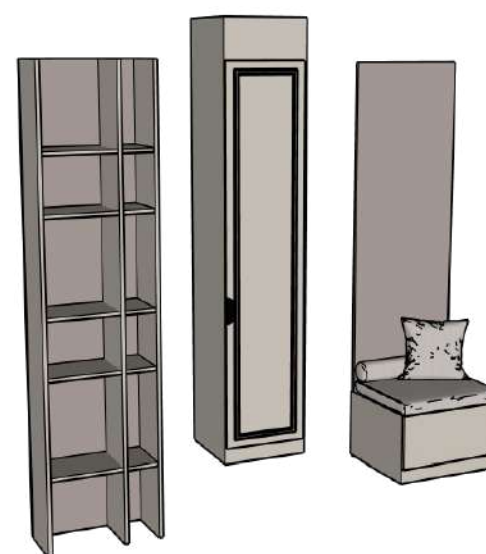

Idejno - izvedbeno rješenje privatnog prostora u Zagrebu
Investitor: Kupac Građanin

M1st design
Dizajner: Matej Kušević
matej.kusevic@m1stdesign.com
+385998218100
m1stdesign.com
svibanj, 2026. godina

IDEJNO IZVEDBENO RJEŠENJE

teh. nacrti namještaj i zidne obloge

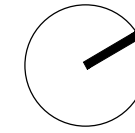

1 POZICIJA SKLADIŠNI ELEMENT

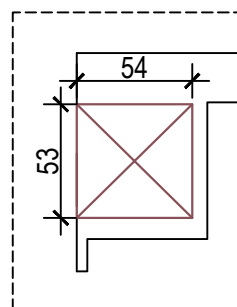
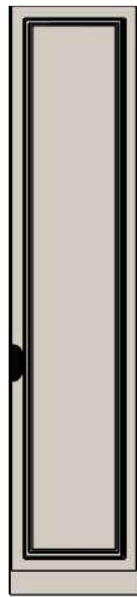

SKLADIŠNI ELEMENT - POGLED

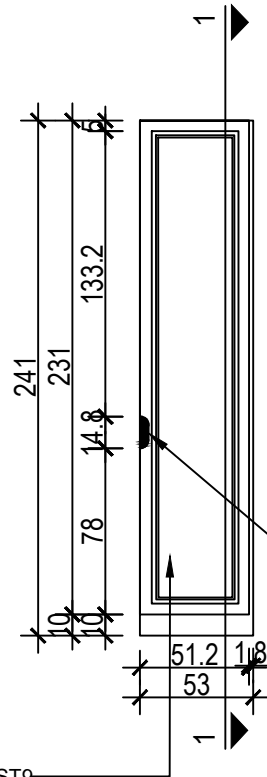

Iverica Egger - U707 ST9
Svileni siva

SKLADIŠNI ELEMENT - SMJER OTVARANJA

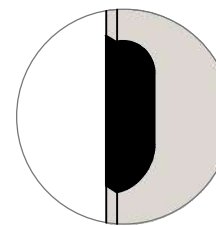
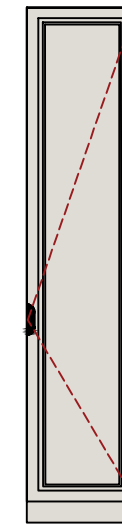

SKLADIŠNI ELEMENT - KORPUS

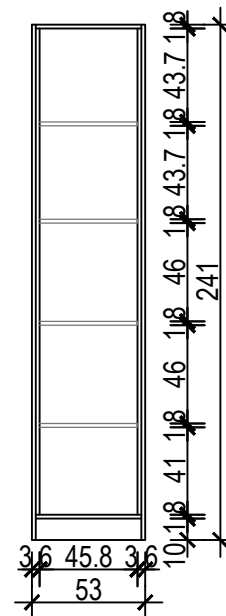

PRESJEK 1-1

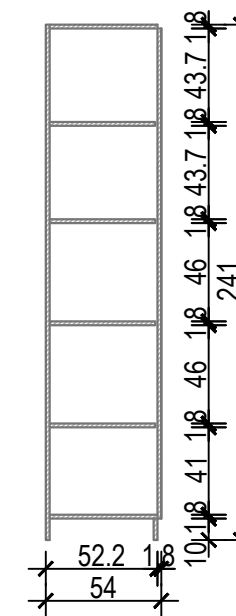

* PRIJE IZVOĐENJA POTREBNO JE UZETI TOČNE MJERE U PROSTORU!
PRIJE IZVOĐENJA POTREBNO JE SVE DEKORE POGLEDATI UŽIVO RADI MOGUĆEG ODSUPANJA U TONU BOJE.



ID.-IZV. RJEŠENJE
teh. nacrti

Idejno - izvedbeno rješenje privatnog prostora u Zagrebu
Investitor: Kupac Građanin

M1st design
Dizajner: Matej Kušević
m1stdesign.com
+385998218100
m1stdesign.com
svibanj, 2026. godina

IDEJNO IZVEDBENO RJEŠENJE

teh. nacrti namještaj i zidne obloge

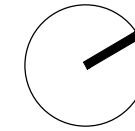

2 POZICIJA KONZOLA

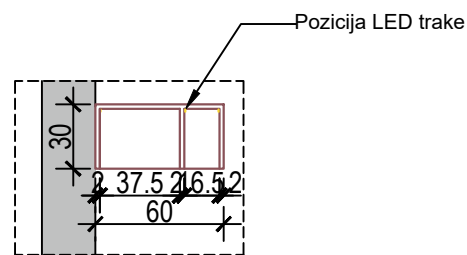
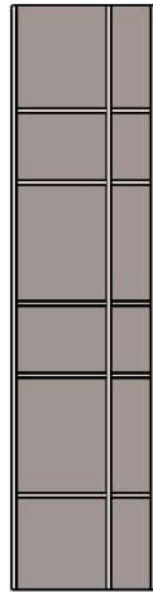

KONZOLA - POGLED

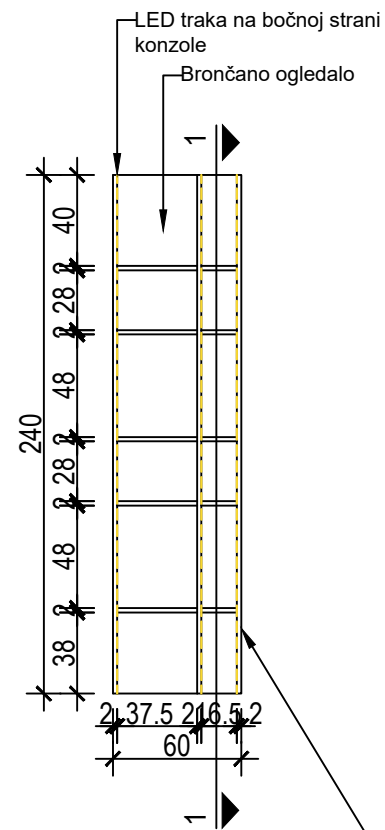

PRESJEK 1-1

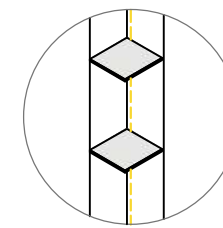
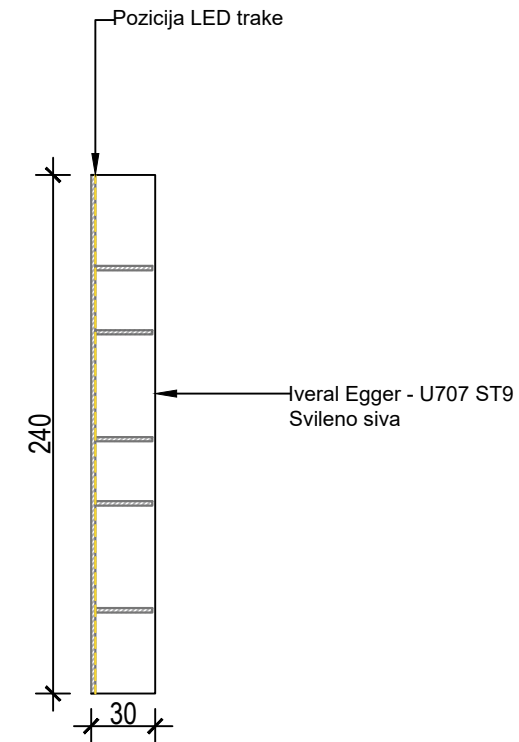

Detalj prikaza pozicije led trake

* PRIJE IZVOĐENJA POTREBNO JE UZETI TOČNE MJERE U PROSTORU!
PRIJE IZVOĐENJA POTREBNO JE SVE DEKORE POGLEDATI UŽIVO RADI MOGUĆEG ODSUPANJA U TONU BOJE.

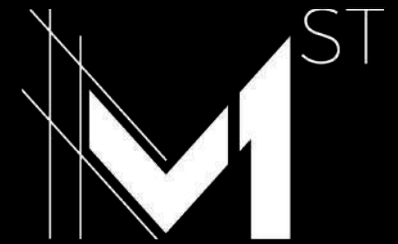

ID.-IZV. RJEŠENJE
teh. nacrti

Idejno - izvedbeno rješenje privatnog prostora u Zagrebu
Investitor: Kupac Građanin

M1st design
Dizajner: Matej Kušević
m1stdesign.com
+385998218100
m1stdesign.com
svibanj, 2026. godina

IDEJNO IZVEDBENO RJEŠENJE

teh. nacrti namještaj i zidne obloge

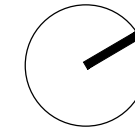

3 POZICIJA KLUPICA

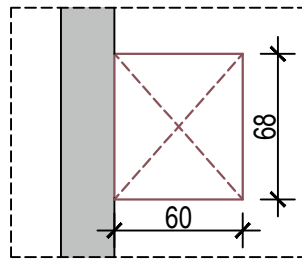

KLUPICA - POGLED

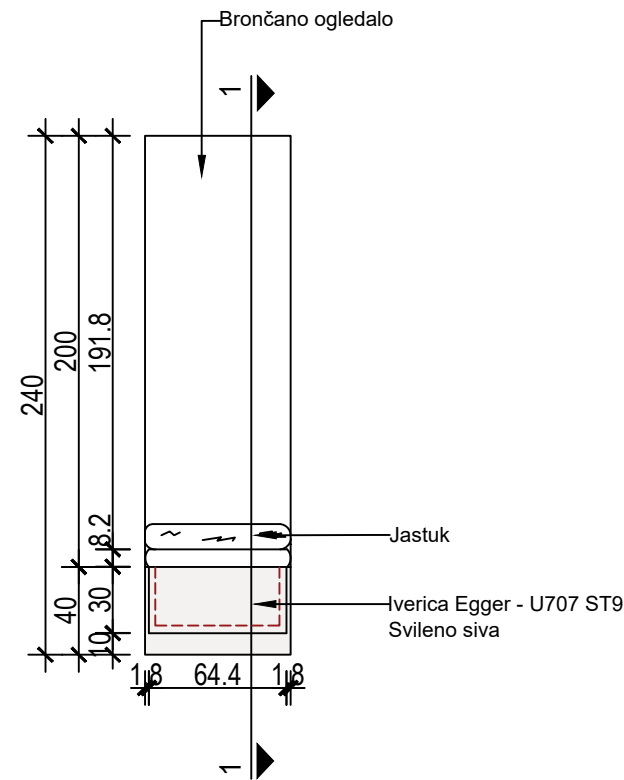

KLUPICA - BOČNI POGLED

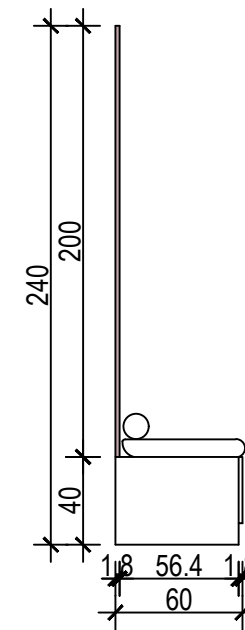

KLUPICA - KORPUS

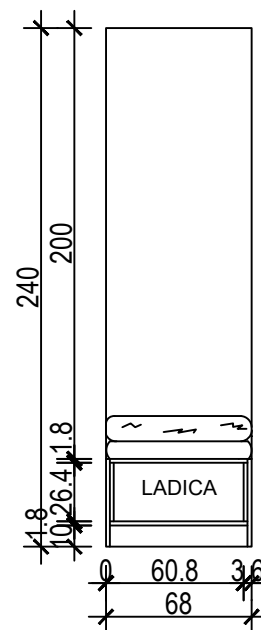

PRESJEK 1 - 1

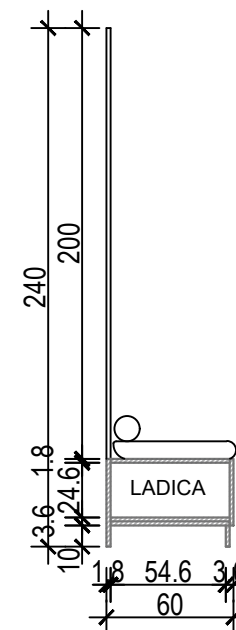

* PRIJE IZVOĐENJA POTREBNO JE UZETI TOČNE MJERE U PROSTORU!
 PRIJE IZVOĐENJA POTREBNO JE SVE DEKORE POGLEDATI UŽIVO RADI MOGUĆEG ODSUPANJA U TONU BOJE.

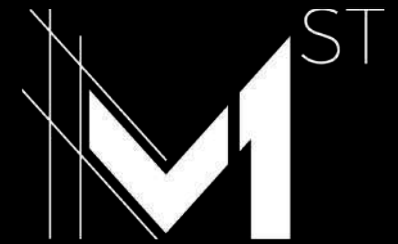

ID.-IZV. RJEŠENJE
 teh. nacrti

Idejno - izvedbeno rješenje privatnog prostora u Zagrebu
 Investitor: Kupac Građanin

M1st design
 Dizajner: Matej Kušević
 matej.kusevic@m1stdesign.com
 +385998218100
 m1stdesign.com
 svibanj, 2026. godina

IDEJNO - IZVEDBENO RJEŠENJE

teh. nacrti namještaj i zidne obloge

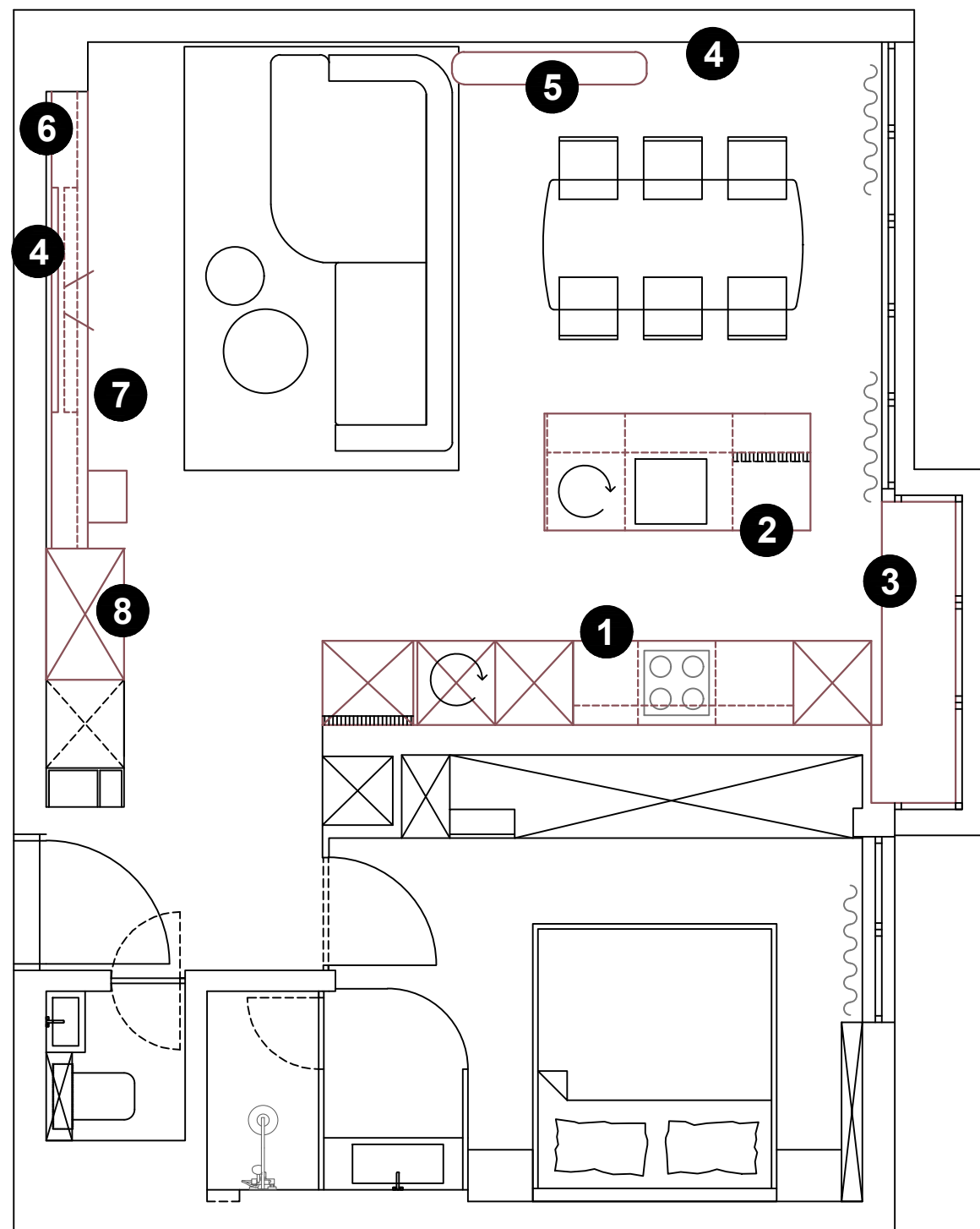

OPEN SPACE

1 i 2) Prostor uključuje kuhinju koja se proteže preko cijelog zida te ima odvojeni otok sa sudoperom. Kuhinja se sastoji od donjih, gornjih i visokih elemenata do stropa. Sistem otvaranja visokih elemenata je tip-on. Gornji elementi se otvaraju na način da se dno elemenata iz fronte zareže kako bi fronte imale napust. Na dnu gornjih elemenata, na 5 cm od unutarnjeg ruba postaviti barisol. Donje elemente i elemente oko aparata 'pur' kantirati. Svi aparati su ugrađeni.

MATERIJAL:

Fronte i fronte: U707 ST9 (svi elementi)

Keramika: Florim - Marble Staturio A (radna ploča i ostrvo)

3) Klupica za sjedenje pod prozorom je smještena s bočne strane kuhinjskih elemenata. Posjeduje jednu ladicu koja se otvara na tip-on sistem.

4) Zid nasuprot kuhinje i iza TV-a je jednostavan sa postavljenim štukaturama u formi velikih pravokutnika.

5) Konzolni stol je dekorativni, samostojeći element čija ploča je napravljena od H3154 ST36 Charleston hrasta u tamno smeđoj nijansi. Noge stola su metalna konstrukcija plastificirana u antracit sivi ton.

6 i 7) TV zid je obložen brončanim ogledalom iza kojeg se postavlja LED traka 3000K, dok se ispod televizora nalazi TV klupa.

MATERIJAL:

Fronte i korpus: H3154 ST36

Keramika: Keramika - Florim: Marble Staturio A

8) Ormar je vrlo jednostavan, s klasičnim otvaranjem, te podijeljen u dva segmenta. Segment s lijeve strane je zamišljen kao gospodarski element za usisivač, sušilo i slično te nekoliko polica za skladištenje. Drugi segment je zamišljen kao dio za klasičnu garderobu u obliku polica i vješanja. S bočne strane prema hodniku na ormar se nastavlja na TV zid.

MATERIJAL:

Fronte i korpus: U707 ST9

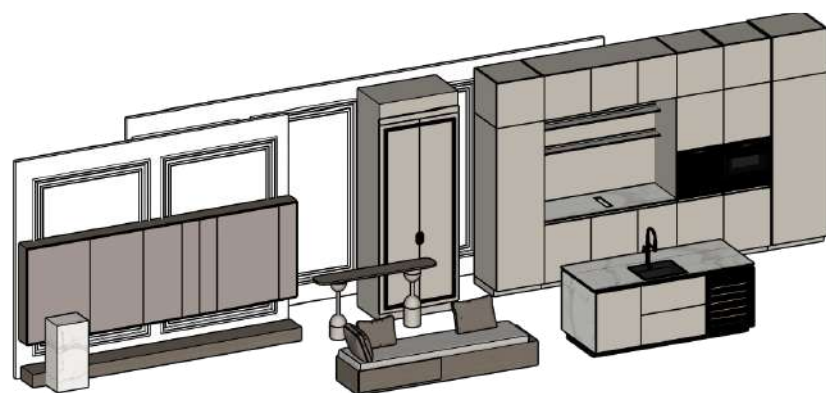

ID.- IZV. RJEŠENJE
teh. nacrti

Idejno - izvedbeno rješenje privatnog prostora u Zagrebu
Investitor: Kupac Građanin

M1st design
Dizajner: Matej Kušević
m1stdesign.com
+385998218100
m1stdesign.com
svibanj, 2026. godina

IDEJNO IZVEDBENO RJEŠENJE

teh. nacrti namještaj i zidne obloge

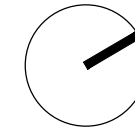

1 POZICIJA KUHINJA

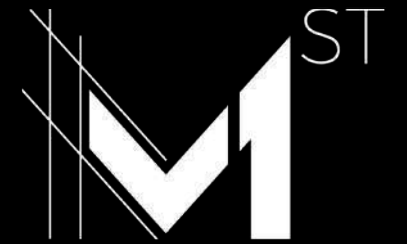
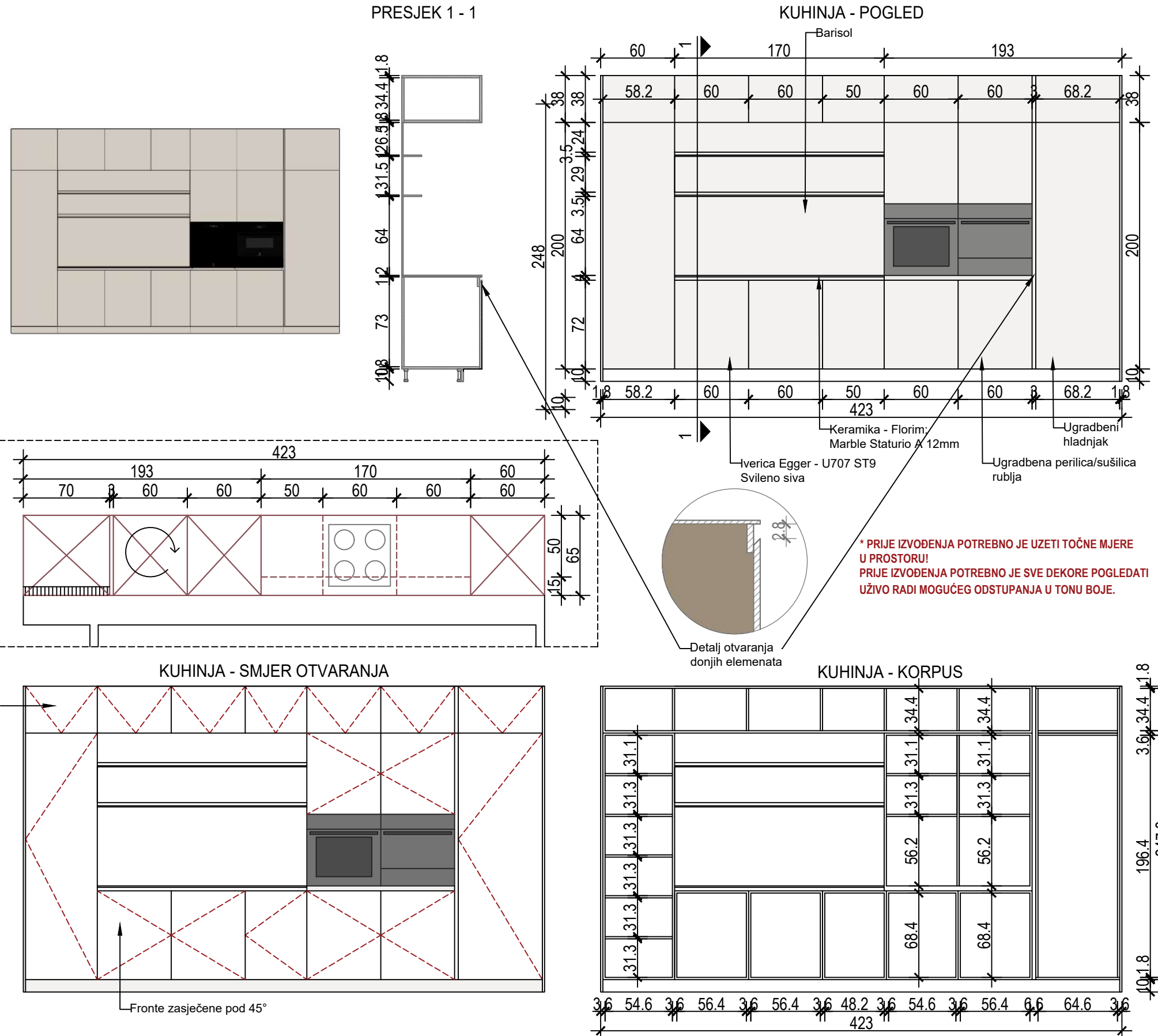

ID.-IZV. RJEŠENJE
teh. nacrti

Idejno - izvedbeno rješenje privatnog prostora u Zagrebu
Investitor: Kupac Građanin

M1st design
Dizajner: Matej Kušević
m1stdesign.com
+385998218100
m1stdesign.com
svibanj, 2026. godina

IDEJNO IZVEDBENO RJEŠENJE

teh. nacrti namještaj i zidne obloge

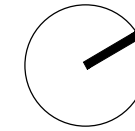

2 POZICIJA 'OTOKA'

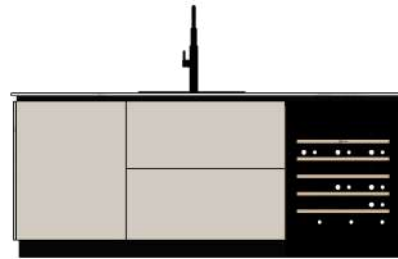

OTOK - POGLED

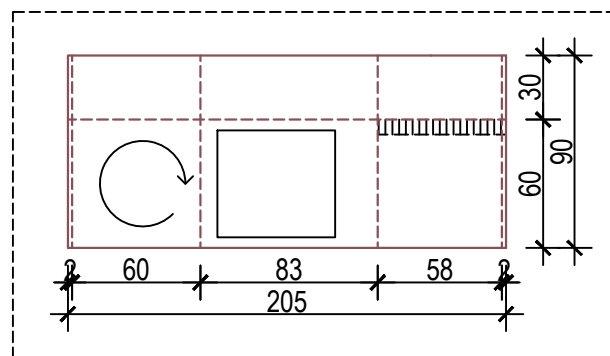
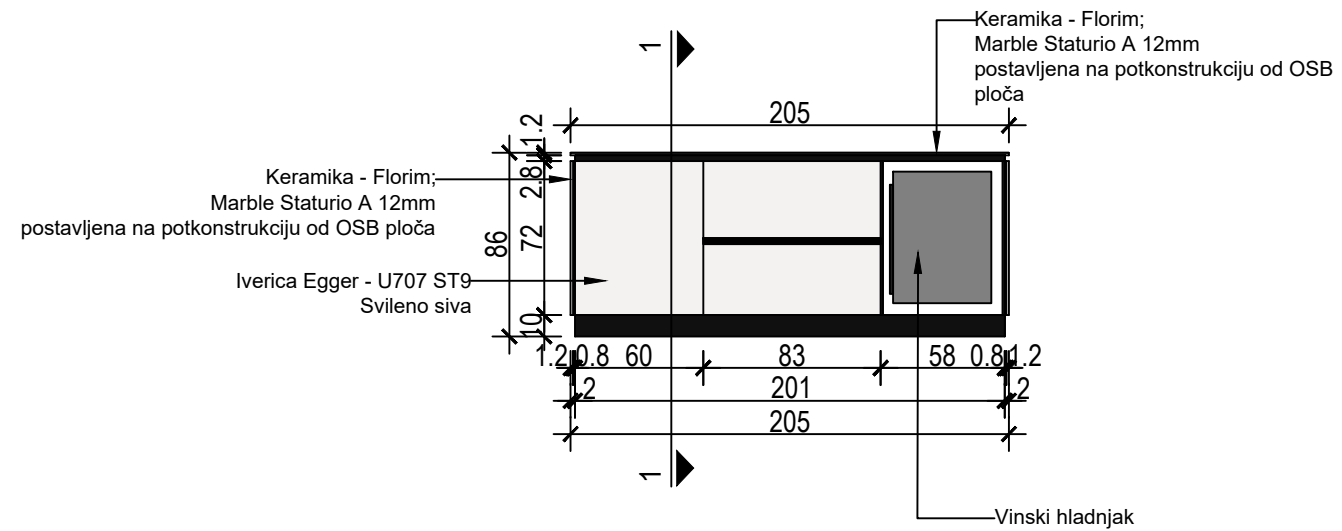

OTOK - SMJER OTVARANJA

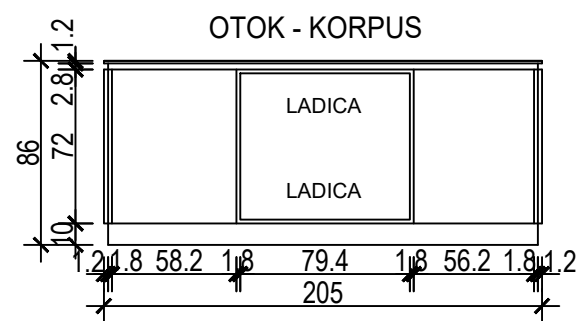
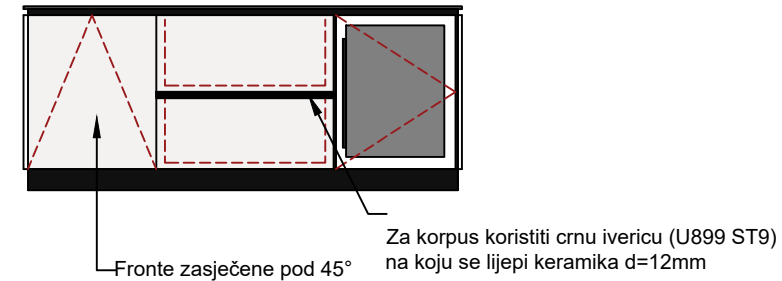

PRESJEK 1 - 1

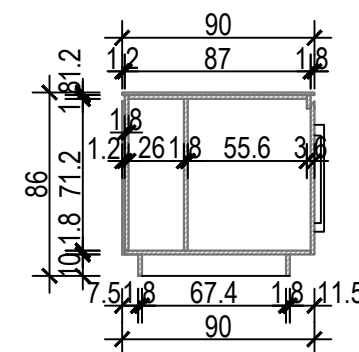

* PRIJE IZVOĐENJA POTREBNO JE UZETI TOČNE MJERE U PROSTORU!
 PRIJE IZVOĐENJA POTREBNO JE SVE DEKORE POGLEDATI UŽIVO RADI MOGUĆEG ODSUPANJA U TONU BOJE.

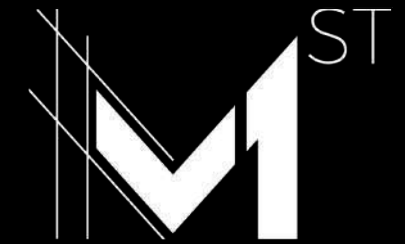

ID.-IZV. RJEŠENJE
 teh. nacrti

Idejno - izvedbeno rješenje privatnog prostora u Zagrebu
 Investitor: Kupac Građanin

M1st design
 Dizajner: Matej Kušević
 matej.kusevic@m1stdesign.com
 +385998218100
 m1stdesign.com
 svibanj, 2026. godina

IDEJNO IZVEDBENO RJEŠENJE

teh. nacrti namještaj i zidne obloge

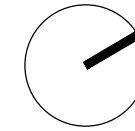

3 KLUPICA ZA SJEDENJE POD PROZOROM



KLUPICA ZA SJEDENJE - POGLED

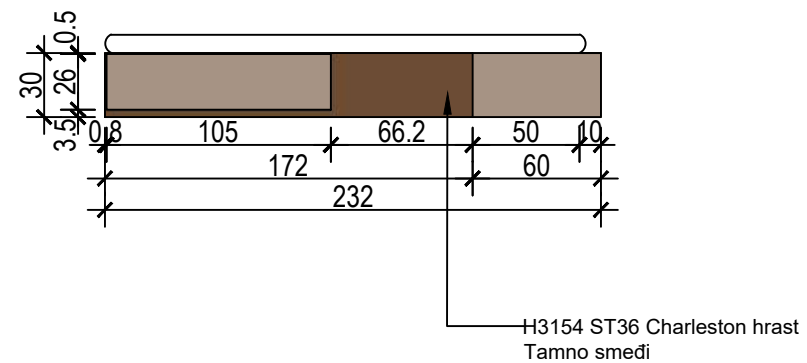

KLUPICA ZA SJEDENJE - SMJER OTVARANJA

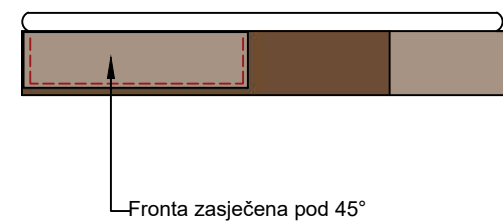

KLUPICA ZA SJEDENJE - KORPUS

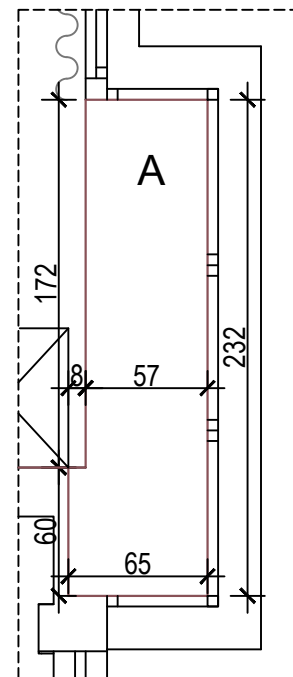
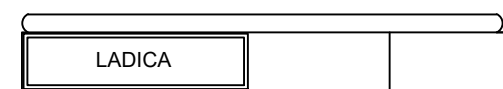

* PRIJE IZVOĐENJA POTREBNO JE UZETI TOČNE MJERE U PROSTORU!
PRIJE IZVOĐENJA POTREBNO JE SVE DEKORE POGLEDATI UŽIVO RADI MOGUĆEG ODSUPANJA U TONU BOJE.

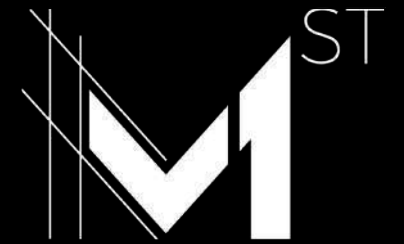

ID.-IZV. RJEŠENJE
teh. nacrti

Idejno - izvedbeno rješenje privatnog prostora u Zagrebu
Investitor: Kupac Građanin

M1st design
Dizajner: Matej Kušević
matej.kusevic@m1stdesign.com
+385998218100
m1stdesign.com
svibanj, 2026. godina

IDEJNO IZVEDBENO RJEŠENJE

teh. nacrti namještaj i zidne obloge

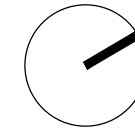

4 POZICIJA ŠTUKATURE OPEN SPACE

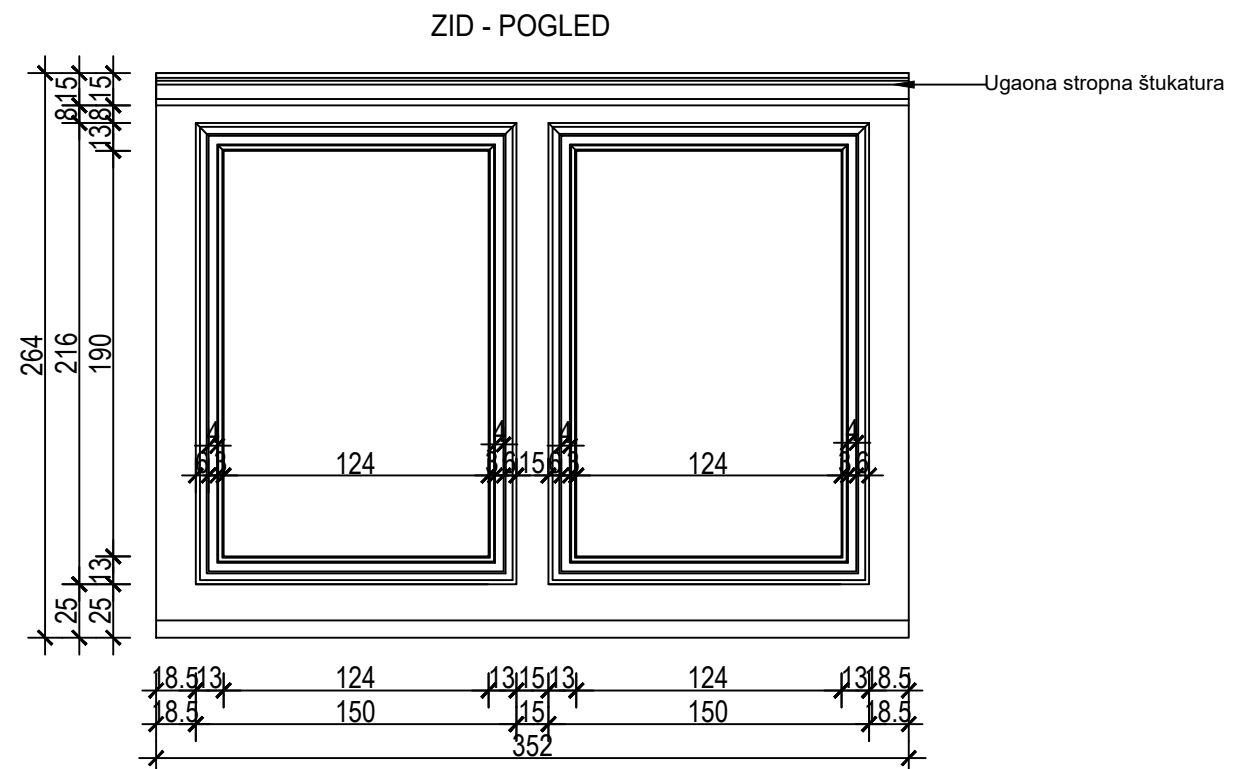
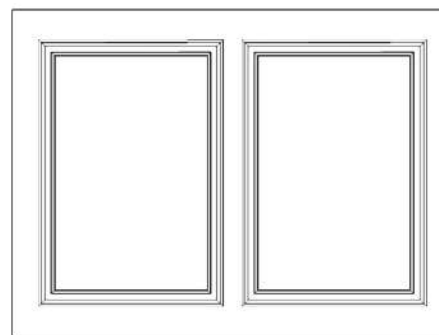
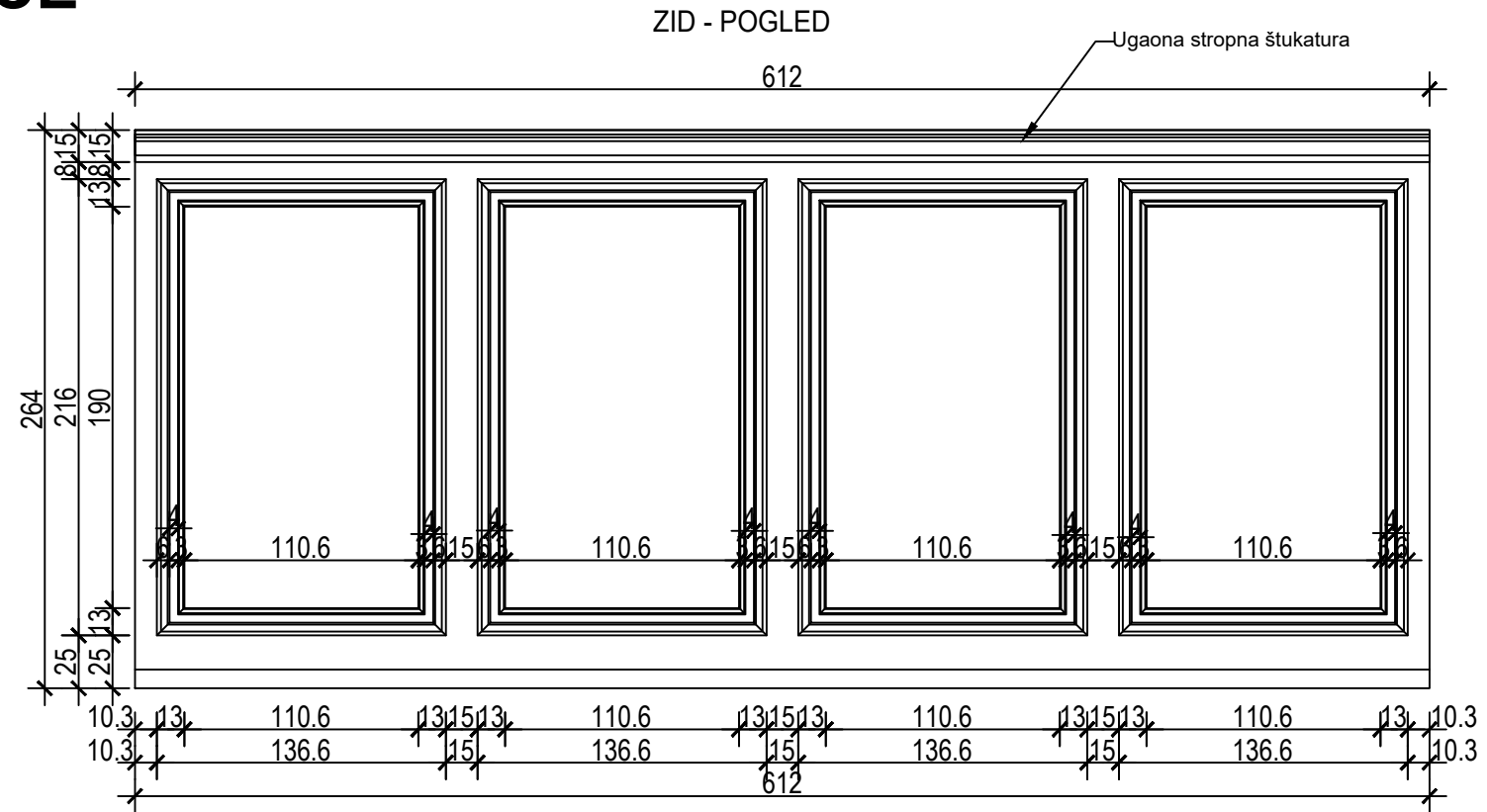
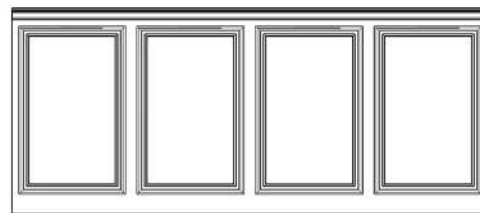

* PRIJE IZVOĐENJA POTREBNO JE UZETI TOČNE MJERE
U PROSTORU!
PRIJE IZVOĐENJA POTREBNO JE SVE DEKORE POGLEDATI
UŽIVO RADI MOGUĆEG ODSUPANJA U TONU BOJE.



ID.-IZV. RJEŠENJE
teh. nacrti

Idejno - izvedbeno rješenje privatnog prostora u Zagrebu
Investitor: Kupac Građanin

M1st design
Dizajner: Matej Kušević
matej.kusevic@m1stdesign.com
+385998218100
m1stdesign.com
svibanj, 2026. godina

IDEJNO IZVEDBENO RJEŠENJE

teh. nacrti namještaj i zidne obloge

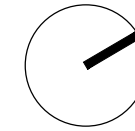

5 POZICIJA KONZOLNI STOL

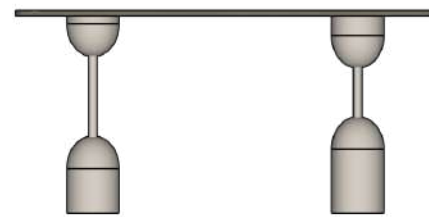

KONZOLNI STOL - POGLED

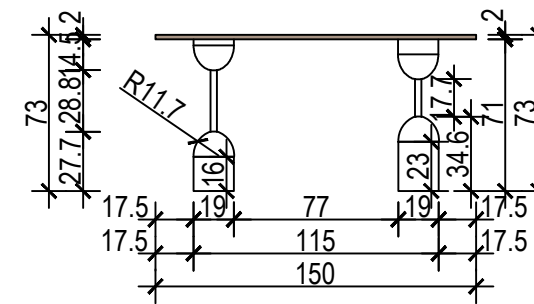

KONZOLNI STOL - BOČNI POGLED

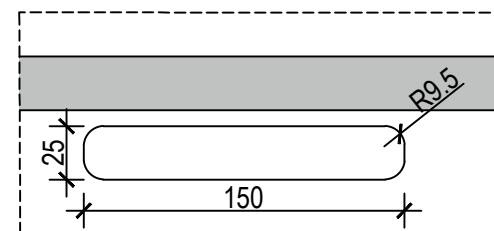
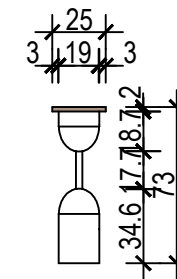

* PRIJE IZVOĐENJA POTREBNO JE UZETI TOČNE MJERE U PROSTORU!
PRIJE IZVOĐENJA POTREBNO JE SVE DEKORE POGLEDATI UŽIVO RADI MOGUĆEG ODSUPANJA U TONU BOJE.



ID.-IZV. RJEŠENJE
teh. nacrti

Idejno - izvedbeno rješenje privatnog prostora u Zagrebu
Investitor: Kupac Građanin

M1st design
Dizajner: Matej Kušević
m1stdesign.com
+385998218100
m1stdesign.com
svibanj, 2026. godina

IDEJNO IZVEDBENO RJEŠENJE

teh. nacrti namještaj i zidne obloge

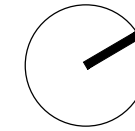

6 POZICIJA TV ZID

7 POZICIJA TV KLUPA

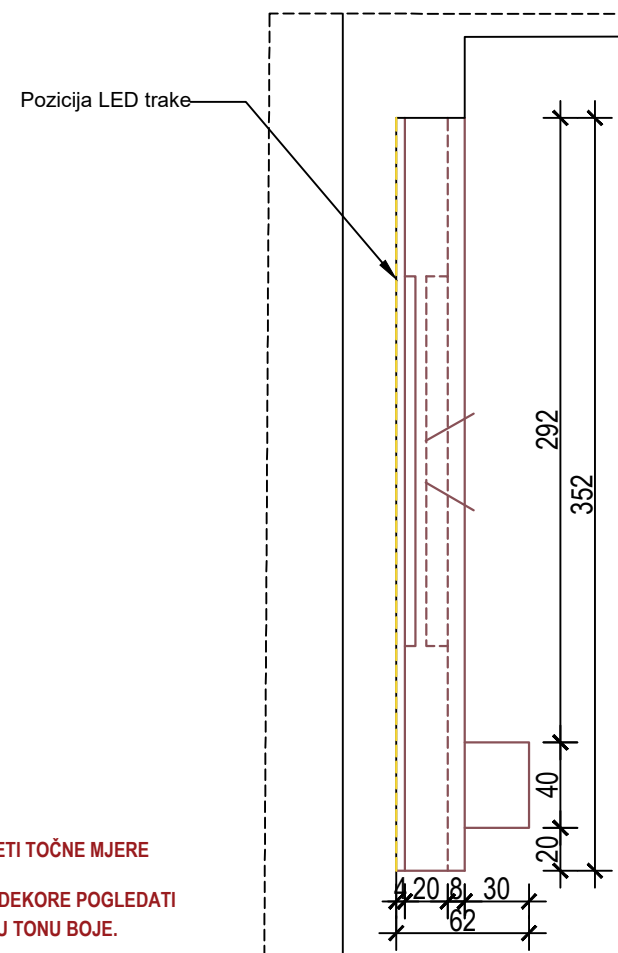
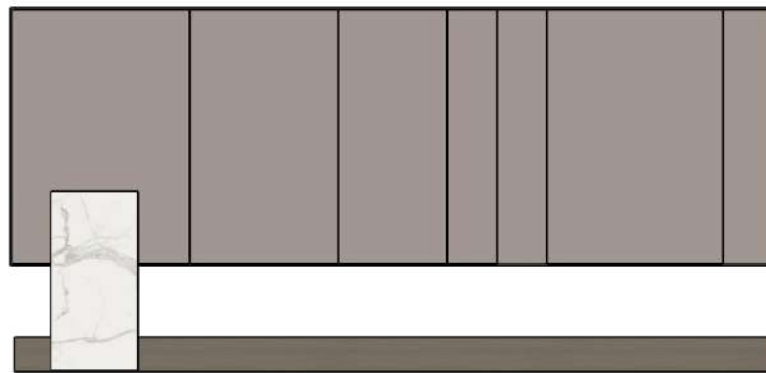

* PRIJE IZVOĐENJA POTREBNO JE UZETI TOČNE MJERE U PROSTORU!
 PRIJE IZVOĐENJA POTREBNO JE SVE DEKORE POGLEDATI UŽIVO RADI MOGUĆEG ODSUPANJA U TONU BOJE.

TV ZID I TV KLUPA - POGLED

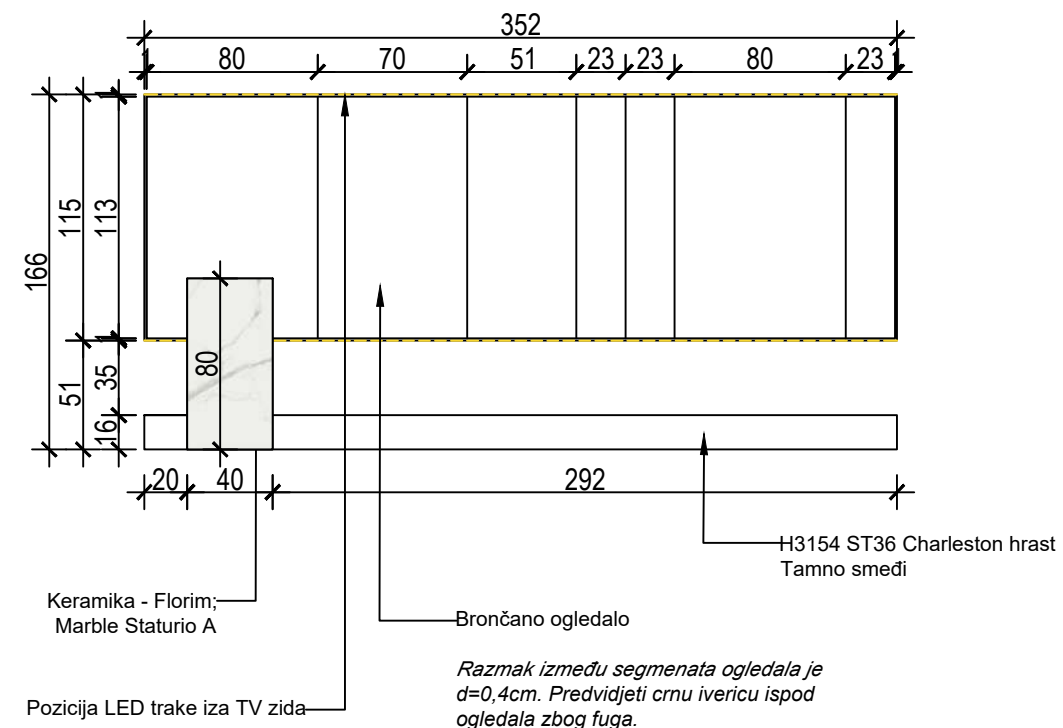

TV ZID I TV KLUPA - BOČNI POGLED

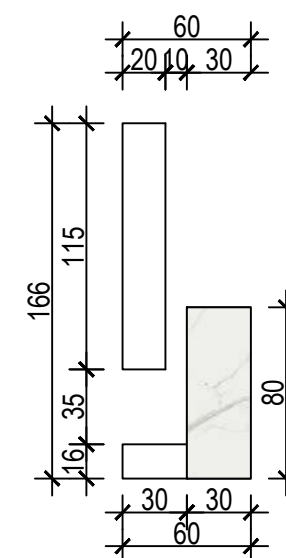

ID.-IZV. RJEŠENJE
 teh. nacrti

Idejno - izvedbeno rješenje privatnog prostora u Zagrebu
 Investitor: Kupac Građanin

M1st design
 Dizajner: Matej Kušević
 matej.kusevic@m1stdesign.com
 +385998218100
 m1stdesign.com
 svibanj, 2026. godina

IDEJNO - IZVEDBENO RJEŠENJE

teh. nacrti namještaj i zidne obloge



ID.- IZV. RJEŠENJE

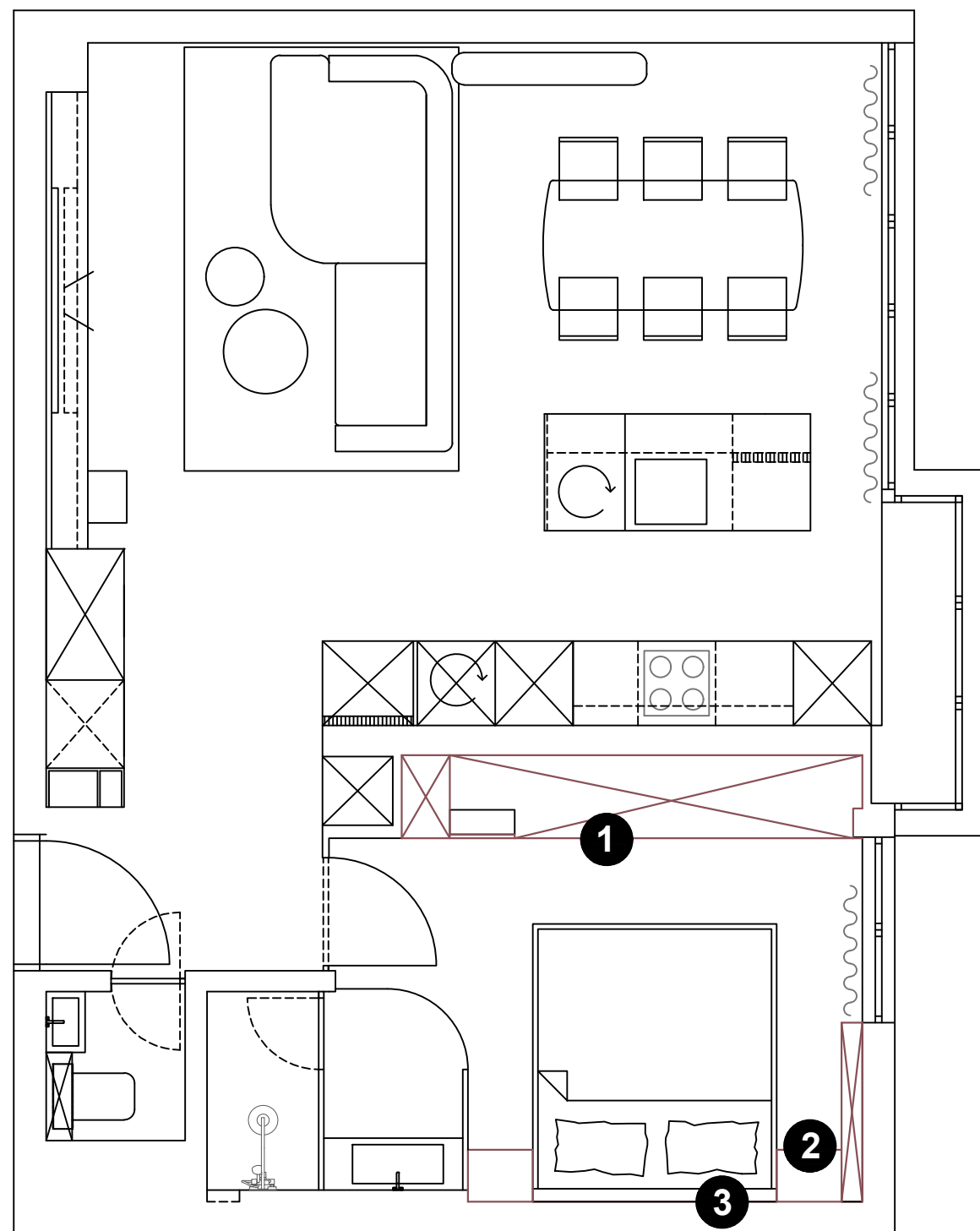

SPAVAĆA SOBA

1) Glavni garderobni ormar spavaće sobe je izveden u dvije dubine s obzirom na stub. Sastoji se od 5 segmenata u nizu i jednog samostalnog koji su u punoj dubini i zamišljeni primarno kao zone za vješanje, uz dodatak polica i 3 ladice. Stub je maskiran brončanim ogledalom koje je fiksni dio, dok su ostali s klasičnim otvaranjem. Dvije fronte su izvedene u brončanom ogledalu, dok ostale imaju klasičnu obradu.

MATERIJAL:

Fronte i korpus: U705 ST9

2) Oko kreveta se smjestio plitki element sa noćnim ormarićima i zidnom oblogom iza koje je pozicionirana LED traka 3000K. Zid iza kreveta je ukrašen štukaturama u obliku velikih pravokutnika. S lijeve strane kreveta se nalazi zid od staklene opeke koji razdvaja dio za spavanje i kupaonicu.

MATERIJAL:

Fronte, obloga i korpus: H3154 ST36

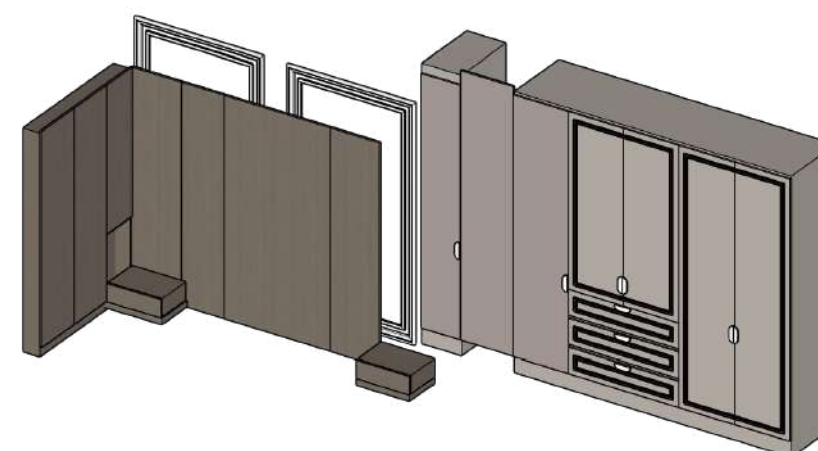

Idejno - izvedbeno rješenje privatnog prostora u Zagrebu
Investitor: Kupac Građanin

M1st design
Dizajner: Matej Kušević
matej.kusevic@m1stdesign.com
+385998218100
m1stdesign.com
svibanj, 2026. godina

IDEJNO IZVEDBENO RJEŠENJE

teh. nacrti namještaj i zidne obloge

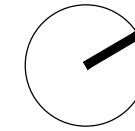

2 POZICIJA PLITKI ELEMENT I ZIDNA OBLOGA

3 POZICIJA ŠTUKATURE

POZICIJA 2.1 - ZIDNA OBLOGA I NOĆNI ORMARIĆI

ZIDNA OBLOGA - POGLED

NOĆNI ORMARIĆI - SMJER OTVARANJA

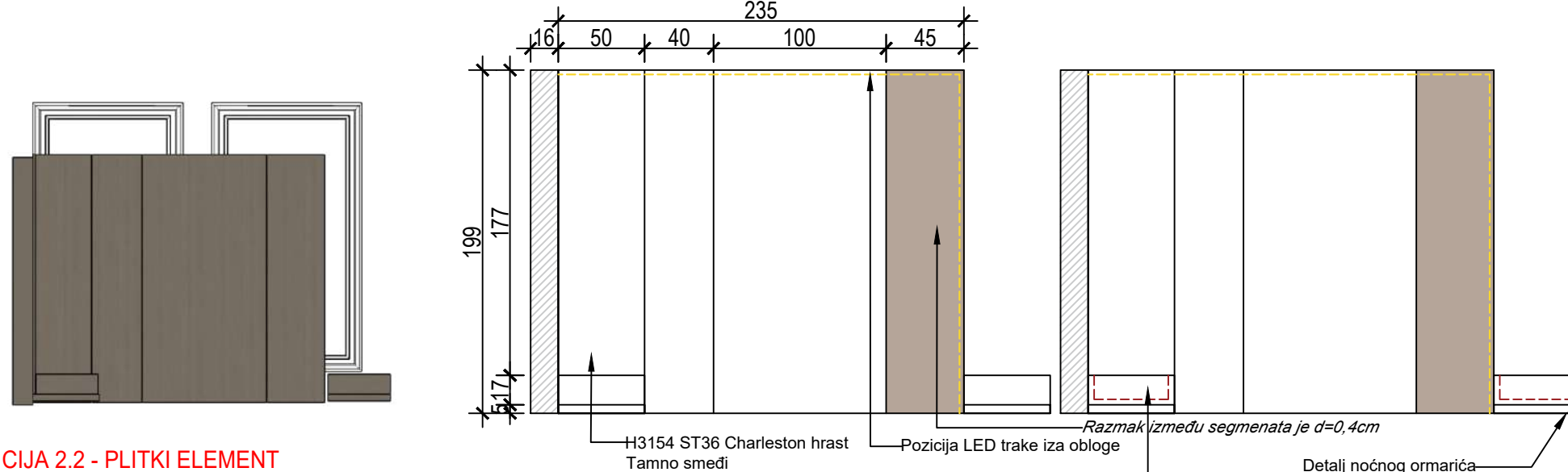

POZICIJA 2.2 - PLITKI ELEMENT

PLITKI ELEMENT - POGLED

PLITKI ELEMENT - KORPUS

NOĆNI ORMARIĆI - KORPUS

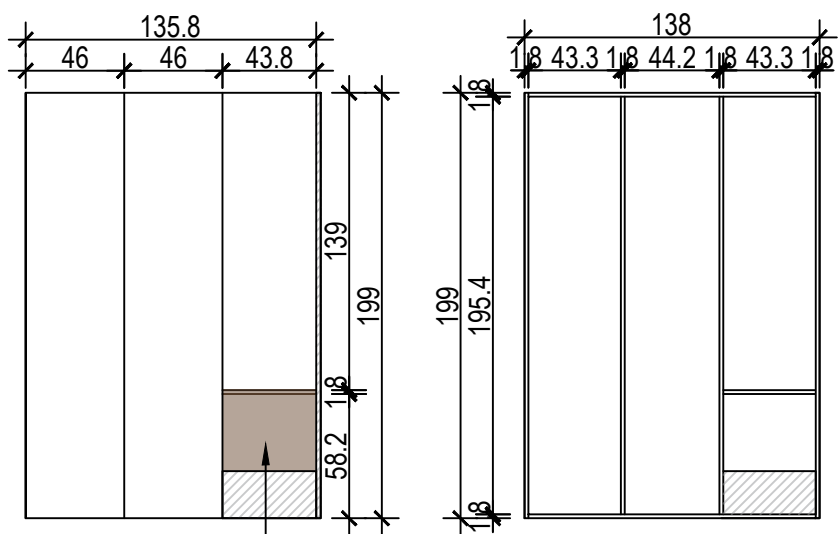

POZICIJA 3 - ŠTUKATURE

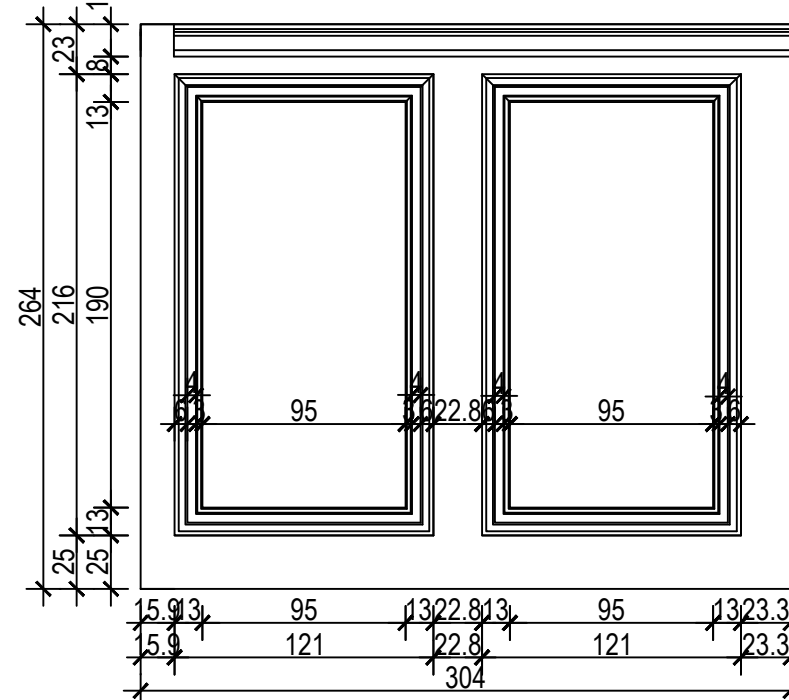

* PRIJE IZVOĐENJA POTREBNO JE UZETI TOČNE MJERE U PROSTORU! PRIJE IZVOĐENJA POTREBNO JE SVE DEKORE POGLEDATI UŽIVO RADI MOGUĆEG ODSUPANJA U TONU BOJE.

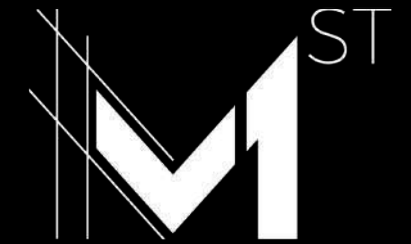

ID.-IZV. RJEŠENJE
teh. nacrti

Idejno - izvedbeno rješenje privatnog prostora u Zagrebu
Investitor: Kupac Građanin

M1st design
Dizajner: Matej Kušević
m1stdesign.com
+385998218100
m1stdesign.com
svibanj, 2026. godina

IDEJNO - IZVEDBENO RJEŠENJE

teh. nacrti namještaj i zidne obloge



ID.- IZV. RJEŠENJE
teh. nacrti

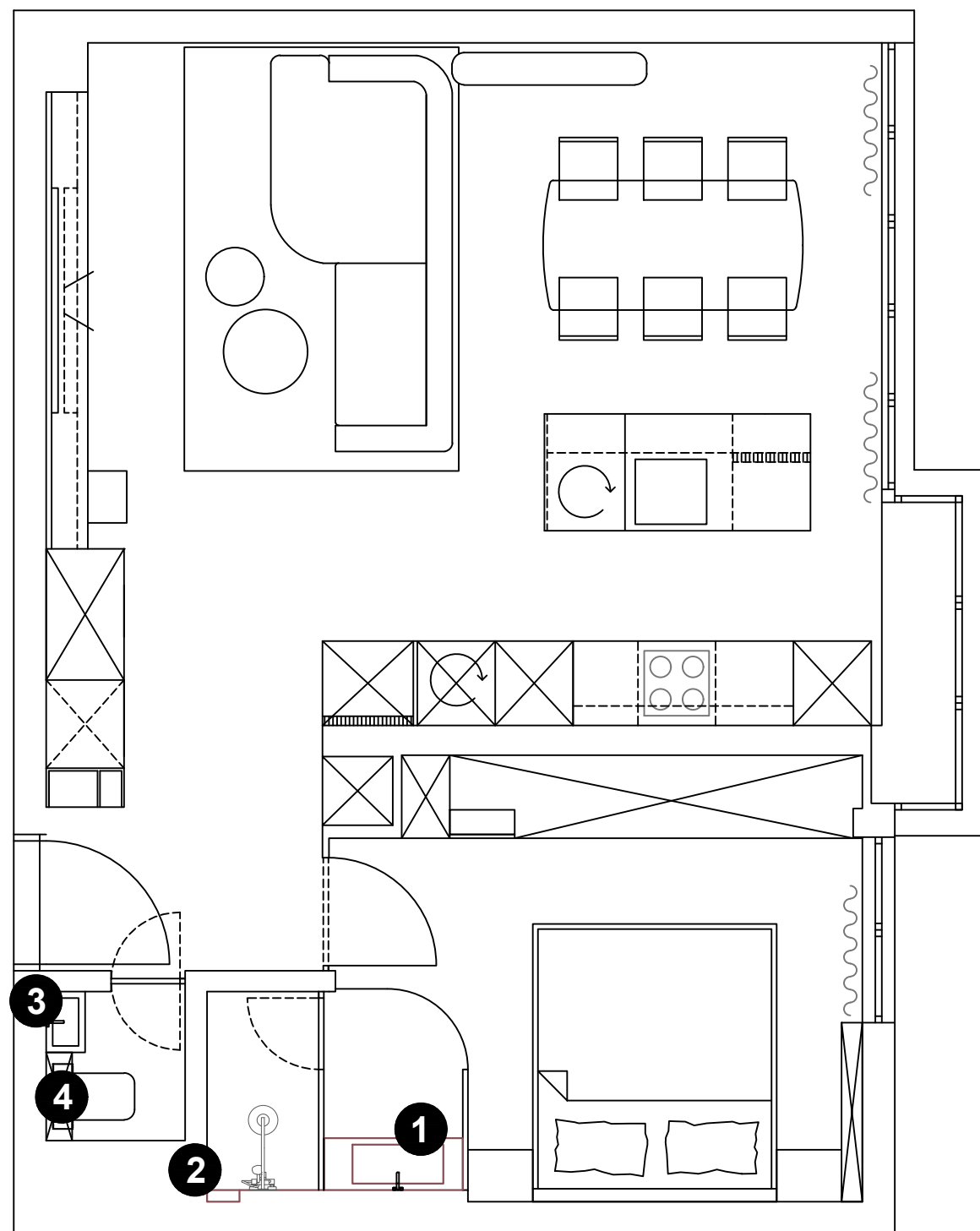

KUPAONICA I TOALET

1) Umivaonik se smjestio na konzoli i ukopan je u keramičkom bloku. Iza ogledala ugraditi LED traku 3000K te zid ukrasiti sa štukaturom.

MATERIJAL:

Florim - Étoile Renoir
Korpus: U705 ST9

2) Zid i niša u walk-in tušu su obloženi keramikom Florim - Étoile Renoir do samog stropa. Niša se sastoji od 5 staklenih polica postavljenih na L nosače. Sa bočnih strana su postavljene LED trake 3000K.

MATERIJAL:

Florim - Étoile Renoir 280 x 120cm

3 i 4) Umivaonik je ukopan u monolitnom obliku u keramičkom bloku. Sa strane se na umivaonik naslanja visoki element za spremanje koji je izveden iz dvije fronte koje se otvaraju na tip-on sistem. Ispod ogledala ugraditi LED traku 3000K. Zid s bočne strane do stropa obložen brončanim ogledalom. Zid naspram umivaonika ukrašen štukaturom.

MATERIJAL:

Florim - Étoile Renoir
Korpus i fronte: U705 ST9

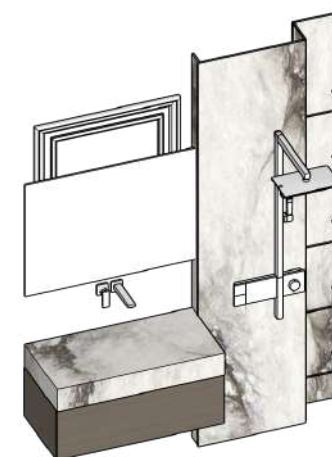

Idejno - izvedbeno rješenje privatnog prostora u Zagrebu
Investitor: Kupac Građanin

M1st design
Dizajner: Matej Kušević
matej.kusevic@m1stdesign.com
+385998218100
m1stdesign.com
svibanj, 2026. godina

IDEJNO IZVEDBENO RJEŠENJE

teh. nacrti namještaj i zidne obloge

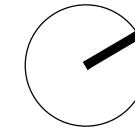

- 3 POZICIJA KONZOLA ZA UMIVAONIK I OGLEDALO**
- 4 POZICIJA SKLADIŠNI PROSTOR**

KONZOLA ZA UMIVAONIK I OGLEDALO

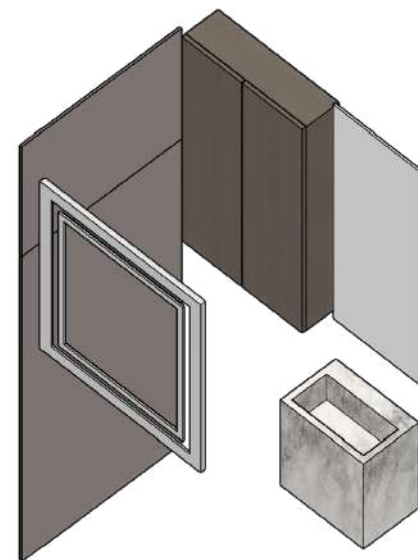

POGLED

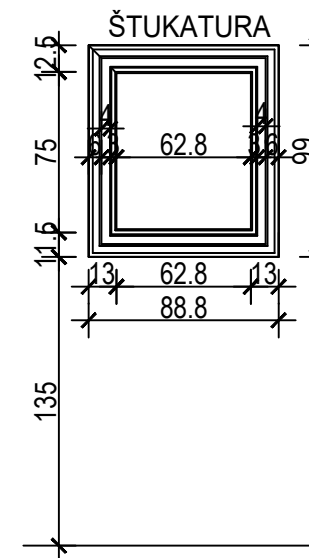
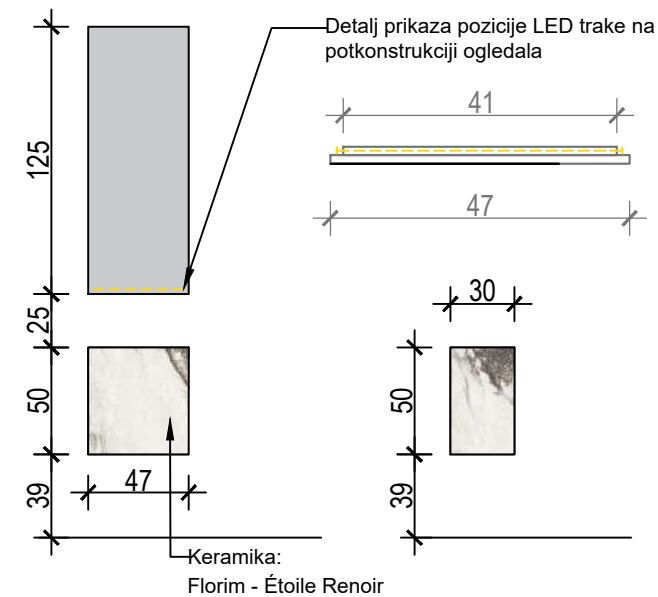

SKLADIŠNI PROSTOR IZNAD UGRADNOG VODOKOTLIČA

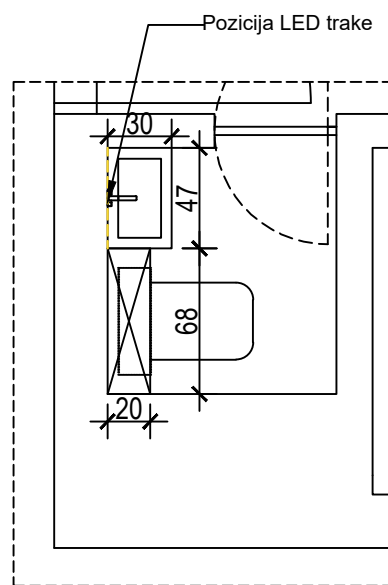

POGLED

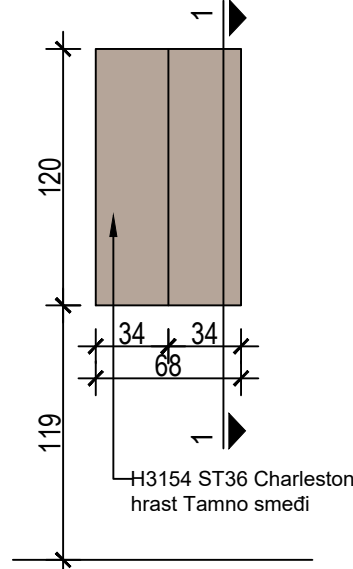

SMJER OTVARANJA

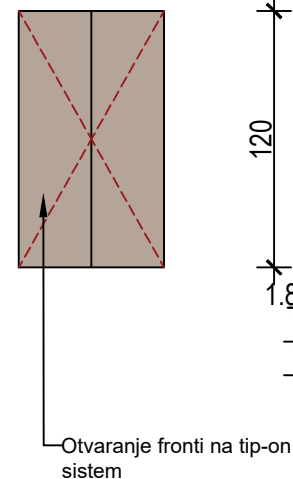

KORPUS

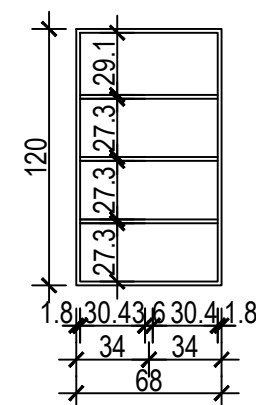

PRESJEK 1 - 1

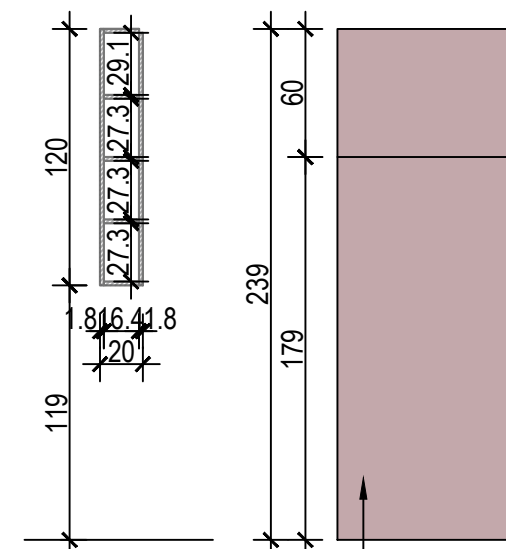

Brončano ogledalo
Razmak između segmenata ogledala je d=0,4cm.

* PRIJE IZVOĐENJA POTREBNO JE UZETI TOČNE MJERE U PROSTORU!
PRIJE IZVOĐENJA POTREBNO JE SVE DEKORE POGLEDATI UŽIVO RADI MOGUĆEG ODSUPANJA U TONU BOJE.

Idejno - izvedbeno rješenje privatnog prostora u Zagrebu
Investitor: Kupac Građanin

M1st design
Dizajner: Matej Kušević
matej.kusevic@m1stdesign.com
+385998218100
m1stdesign.com
svibanj, 2026. godina

POZICIJE IZVODA I UTIČNICA

IDEJNO - IZVEDBENO RJEŠENJE tlocrt elektro instalacija

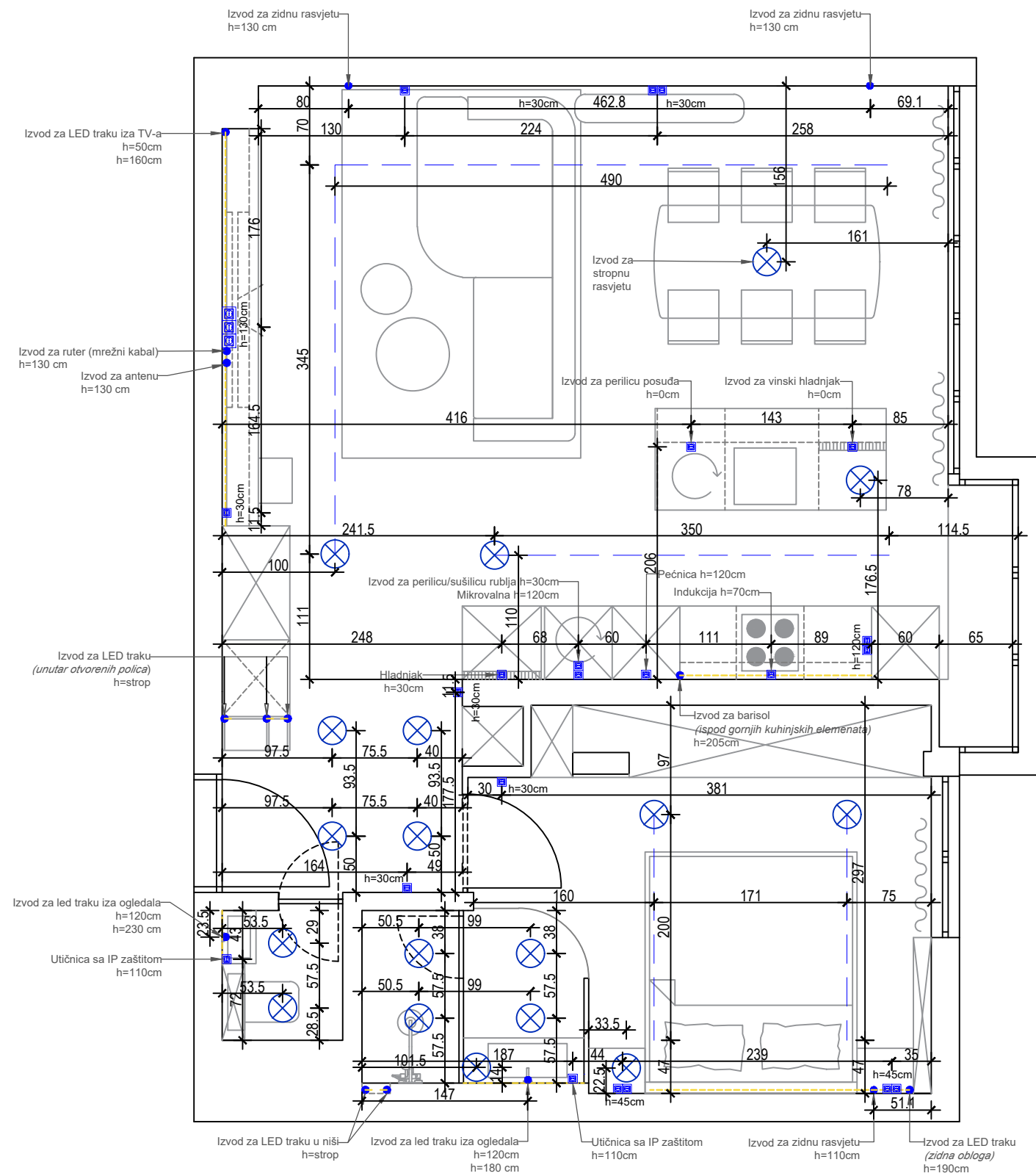
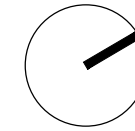

NAPOMENA:
LED rasvjetu koja je ugrađena ispod elemenata, u vitrinama, iza panela, ogledala i sl, paliti/gasiti na mali prekidač u blizini izvoda na dostupnom mjestu.

Rasvjetu kod kupaonskih elemenata paliti/gasiti na glavnim prekidačima, ali i na/pored/ispod ogledala.

Predvidjeti el. instalacije klima uređaje, alarmni sustav, video nadzor te sve elemente koji nisu predviđeni dizajnom (u dogovoru sa ovlaštenim osobama).



ID.-IZV. RJEŠENJE tlocrt elektro instalacija

Idejno - izvedbeno rješenje privatnog prostora u Zagrebu
Investitor: Kupac Građanin

M1st design
Dizajner: Matej Kušević
matej.kusevic@m1stdesign.com
+385998218100
m1stdesign.com
svibanj, 2026. godina

IDEJNO - IZVEDBENO RJEŠENJE

tlocrt instalacija vode

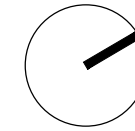

● Nove pozicije vode/odvoda

● Trenutne pozicije vode/odvoda

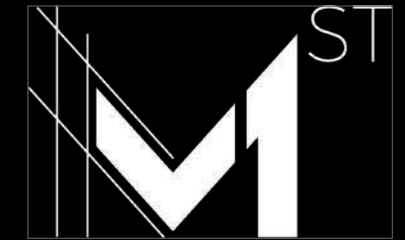
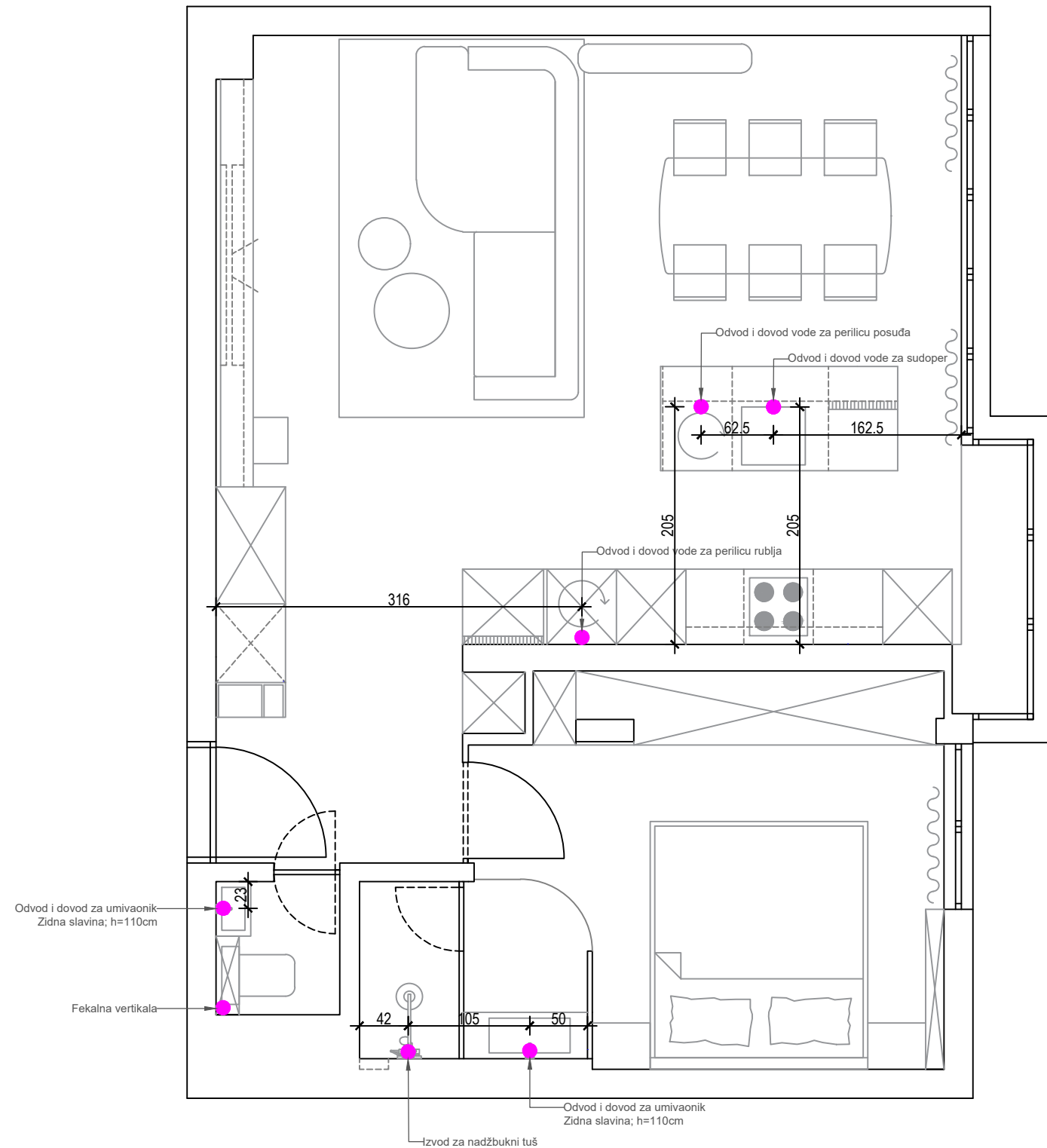

ID.-IZV. RJEŠENJE
tlocrt instalacija vode



Idejno - izvedbeno rješenje privatnog prostora u Zagrebu
Investitor: Kupac Građanin

M1st design
Dizajner: Matej Kušević
m1stdesign.com
+385998218100
m1stdesign.com
svibanj, 2026. godina

IDEJNO - IZVEDBENO RJEŠENJE

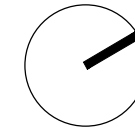
plan spuštenog stopa



-  SPUŠTENI STROP
P= 10.16 m²
-  STROPNA LAJSNA
L= 34.4 m

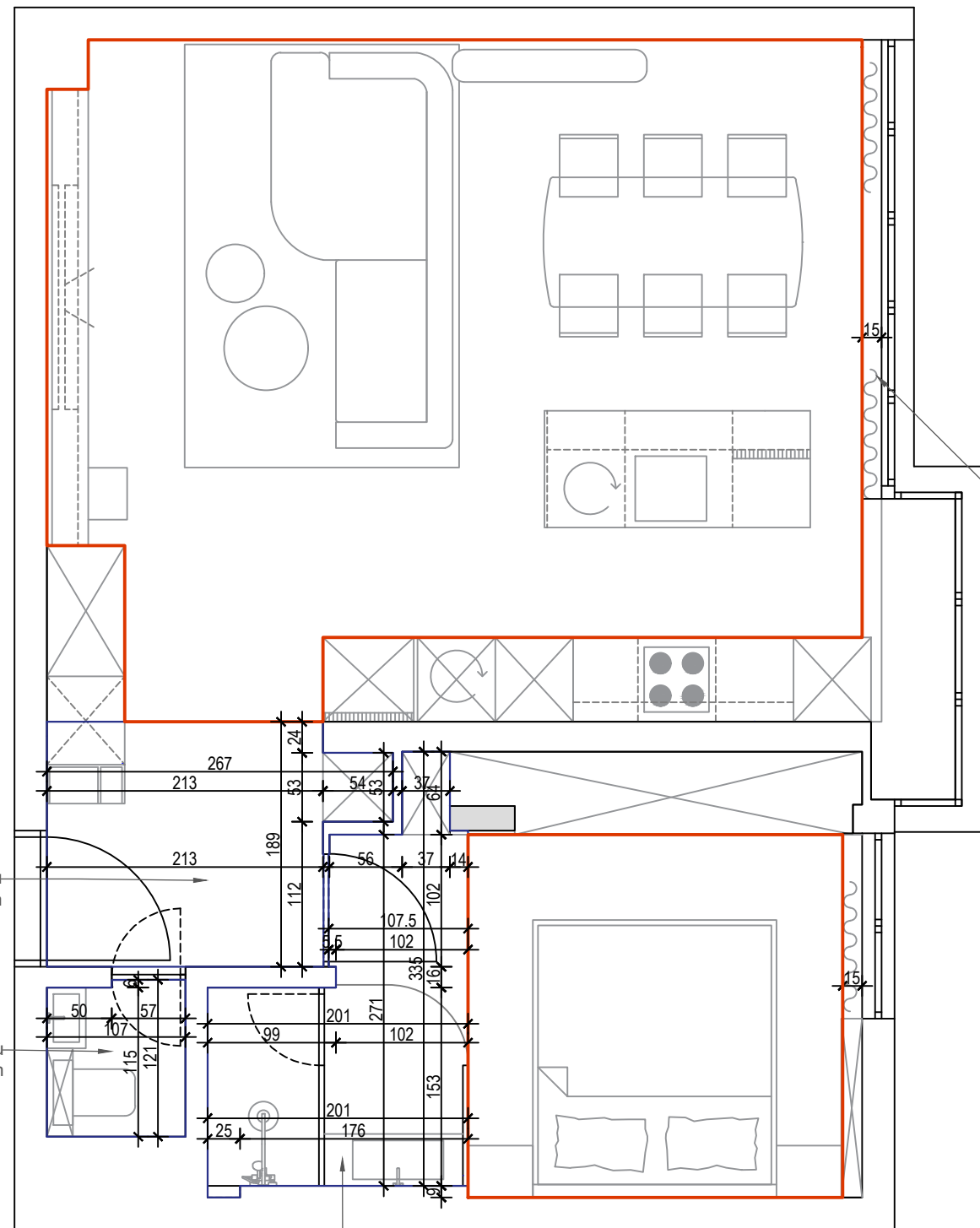

Kota spušenog stropa u odnosu na kotu gotovog poda je h=240cm

Kota spušenog stropa u odnosu na kotu gotovog poda je h=240cm

Kota spušenog stropa u odnosu na kotu gotovog poda je h=230cm (zbog stepenice koja vodi u kupaonicu)

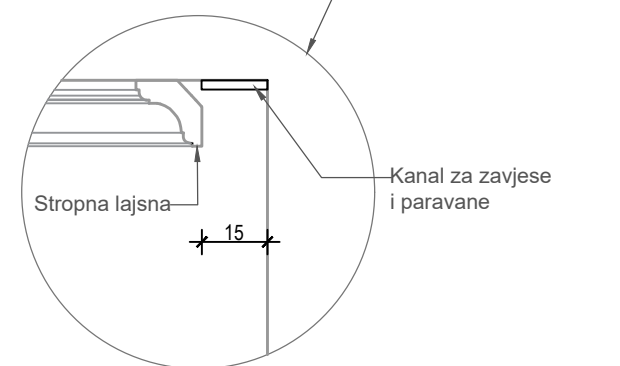

ID.- IZV. RJEŠENJE

plan spušenog stopa

Idejno - izvedbeno rješenje privatnog prostora u Zagrebu
Investitor: Kupac Građanin

M1st design
Dizajner: Matej Kušević
m1stdesign.com
+385998218100
m1stdesign.com
svibanj, 2026. godina

IDEJNO - IZVEDBENO RJEŠENJE

plan štukatura

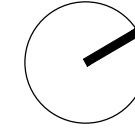

— Štukature

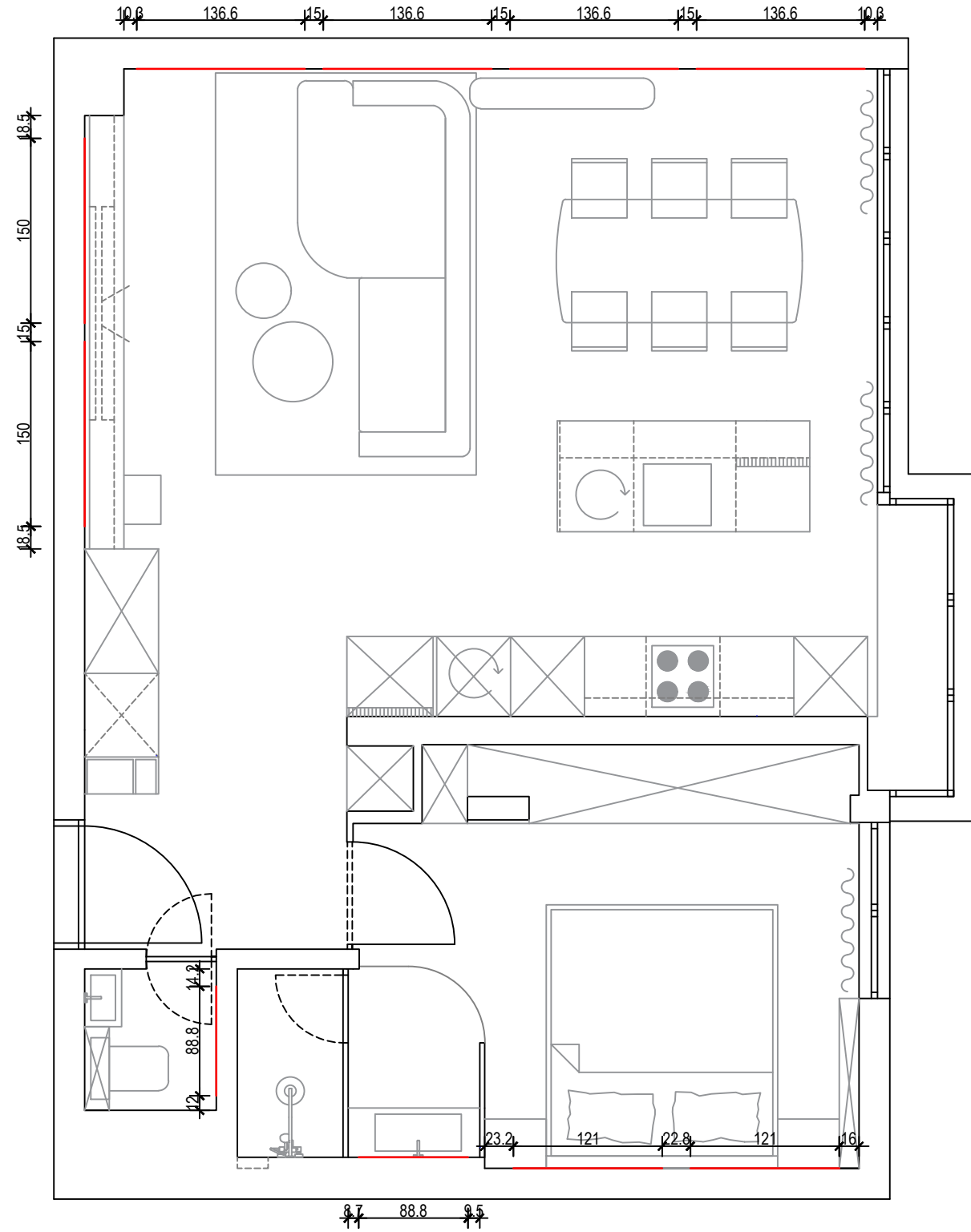

ID.- IZV. RJEŠENJE
plan spušenog stropa

Idejno - izvedbeno rješenje privatnog prostora u Zagrebu
Investitor: Kupac Građanin

M1st design
Dizajner: Matej Kušević
m1stdesign.com
+385998218100
m1stdesign.com
svibanj, 2026. godina

POLAGANJE KERAMIKE



ID.- IZV. RJEŠENJE
polaganje podova

Idejno - izvodbeno rješenje privatnog prostora u Zagrebu
Investitor: Kupac Građanin

M1st design
Dizajner: Matej Kušević
matej.kusevic@m1stdesign.com
+385998218100
m1stdesign.com
svibanj, 2026. godina

IDEJNO - IZVEDBENO RJEŠENJE

polaganje keramike

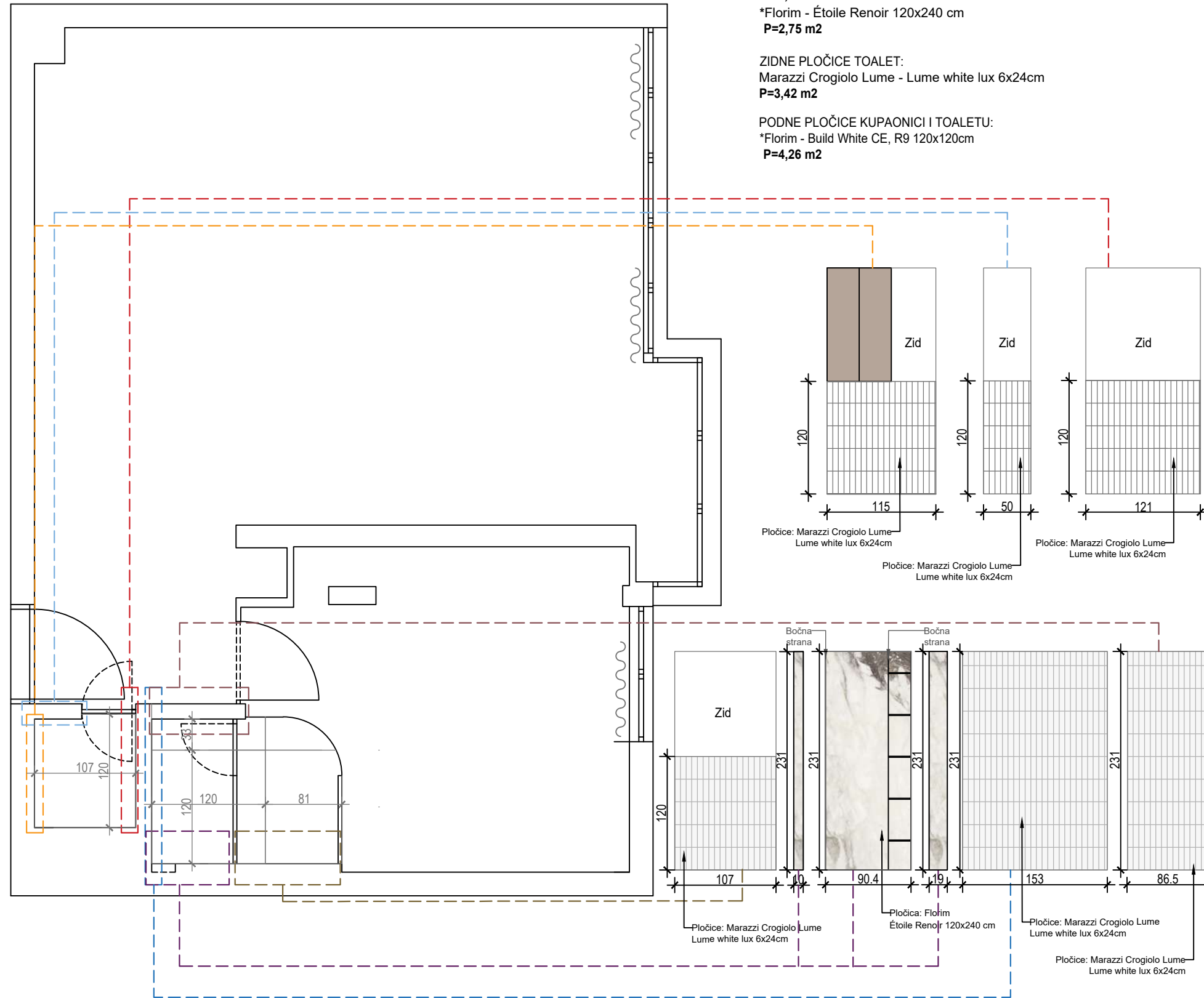
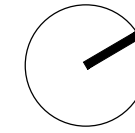

ID.- IZV. RJEŠENJE

polaganje podova

Idejno - izvedbeno rješenje privatnog prostora u Zagrebu
 Investitor: Kupac Građanin

M1st design
 Dizajner: Matej Kušević
 matej.kusevic@m1stdesign.com
 +385998218100
 m1stdesign.com
 svibanj, 2026. godina

VIZUALIZACIJE



ID.- IZV. RJEŠENJE
vizualizacije

Idejno - izvodbeno rješenje privatnog prostora u Zagrebu
Investitor: Kupac Građanin

M1st design
Dizajner: Matej Kušević
matej.kusevic@m1stdesign.com
+385998218100
m1stdesign.com
svibanj, 2026. godina



ID.-IZV. RJEŠENJE
vizualizacije

Idejno - izvedbeno rješenje privatnog prostora u Zagrebu
Investitor: Kupac Građanin

M1st design

Dizajner: Matej Kušević

matej.kusevic@m1stdesign.com

+385998218100

m1stdesign.com

svibanj, 2026. godina



ID.-IZV. RJEŠENJE
vizualizacije

Idejno - izvedbeno rješenje privatnog prostora u Zagrebu
Investitor: Kupac Građanin

M1st design

Dizajner: Matej Kušević

matej.kusevic@m1stdesign.com

+385998218100

m1stdesign.com

svibanj, 2026. godina



ID.-IZV. RJEŠENJE
vizualizacije

Idejno - izvedbeno rješenje privatnog prostora u Zagrebu
Investitor: Kupac Građanin

M1st design

Dizajner: Matej Kušević

matej.kusevic@m1stdesign.com

+385998218100

m1stdesign.com

svibanj, 2026. godina



ID.-IZV. RJEŠENJE
vizualizacije

Idejno - izvedbeno rješenje privatnog prostora u Zagrebu
Investitor: Kupac Građanin

M1st design

Dizajner: Matej Kušević

matej.kusevic@m1stdesign.com

+385998218100

m1stdesign.com

svibanj, 2026. godina



ID.-IZV. RJEŠENJE
vizualizacije

Idejno - izvedbeno rješenje privatnog prostora u Zagrebu
Investitor: Kupac Građanin

M1st design

Dizajner: Matej Kušević

matej.kusevic@m1stdesign.com

+385998218100

m1stdesign.com

svibanj, 2026. godina



ID.-IZV. RJEŠENJE
vizualizacije

Idejno - izvedbeno rješenje privatnog prostora u Zagrebu
Investitor: Kupac Građanin

M1st design

Dizajner: Matej Kušević

matej.kusevic@m1stdesign.com

+385998218100

m1stdesign.com

svibanj, 2026. godina



ID.-IZV. RJEŠENJE
vizualizacije

Idejno - izvedbeno rješenje privatnog prostora u Zagrebu
Investitor: Kupac Građanin

M1st design

Dizajner: Matej Kušević

matej.kusevic@m1stdesign.com

+385998218100

m1stdesign.com

svibanj, 2026. godina



ID.-IZV. RJEŠENJE
vizualizacije

Idejno - izvedbeno rješenje privatnog prostora u Zagrebu
Investitor: Kupac Građanin

M1st design

Dizajner: Matej Kušević

matej.kusevic@m1stdesign.com

+385998218100

m1stdesign.com

svibanj, 2026. godina



ID.-IZV. RJEŠENJE
vizualizacije

Idejno - izvedbeno rješenje privatnog prostora u Zagrebu
Investitor: Kupac Građanin

M1st design

Dizajner: Matej Kušević

matej.kusevic@m1stdesign.com

+385998218100

m1stdesign.com

svibanj, 2026. godina



ID.-IZV. RJEŠENJE
vizualizacije

Idejno - izvedbeno rješenje privatnog prostora u Zagrebu
Investitor: Kupac Građanin

M1st design

Dizajner: Matej Kušević

matej.kusevic@m1stdesign.com

+385998218100

m1stdesign.com

svibanj, 2026. godina



ID.-IZV. RJEŠENJE
vizualizacije

Idejno - izvedbeno rješenje privatnog prostora u Zagrebu
Investitor: Kupac Građanin

M1st design

Dizajner: Matej Kušević

matej.kusevic@m1stdesign.com

+385998218100

m1stdesign.com

svibanj, 2026. godina



ID.-IZV. RJEŠENJE
vizualizacije

Idejno - izvedbeno rješenje privatnog prostora u Zagrebu
Investitor: Kupac Građanin

M1st design

Dizajner: Matej Kušević

matej.kusevic@m1stdesign.com

+385998218100

m1stdesign.com

svibanj, 2026. godina



ID.-IZV. RJEŠENJE
vizualizacije

Idejno - izvedbeno rješenje privatnog prostora u Zagrebu
Investitor: Kupac Građanin

M1st design

Dizajner: Matej Kušević

matej.kusevic@m1stdesign.com

+385998218100

m1stdesign.com

svibanj, 2026. godina



ID.-IZV. RJEŠENJE
vizualizacije

Idejno - izvedbeno rješenje privatnog prostora u Zagrebu
Investitor: Kupac Građanin

M1st design

Dizajner: Matej Kušević

matej.kusevic@m1stdesign.com

+385998218100

m1stdesign.com

svibanj, 2026. godina



ID.-IZV. RJEŠENJE
vizualizacije

Idejno - izvedbeno rješenje privatnog prostora u Zagrebu
Investitor: Kupac Građanin

M1st design
Dizajner: Matej Kušević
matej.kusevic@m1stdesign.com
+385998218100
m1stdesign.com
svibanj, 2026. godina



ID.-IZV. RJEŠENJE
vizualizacije

Idejno - izvedbeno rješenje privatnog prostora u Zagrebu
Investitor: Kupac Građanin

M1st design

Dizajner: Matej Kušević

matej.kusevic@m1stdesign.com

+385998218100

m1stdesign.com

svibanj, 2026. godina



ID.-IZV. RJEŠENJE
vizualizacije

Idejno - izvedbeno rješenje privatnog prostora u Zagrebu
Investitor: Kupac Građanin

M1st design

Dizajner: Matej Kušević

matej.kusevic@m1stdesign.com

+385998218100

m1stdesign.com

svibanj, 2026. godina



ID.-IZV. RJEŠENJE
vizualizacije

Idejno - izvedbeno rješenje privatnog prostora u Zagrebu
Investitor: Kupac Građanin

M1st design

Dizajner: Matej Kušević

matej.kusevic@m1stdesign.com

+385998218100

m1stdesign.com

svibanj, 2026. godina



ID.-IZV. RJEŠENJE
vizualizacije

Idejno - izvedbeno rješenje privatnog prostora u Zagrebu
Investitor: Kupac Građanin

M1st design

Dizajner: Matej Kušević

matej.kusevic@m1stdesign.com

+385998218100

m1stdesign.com

svibanj, 2026. godina



ID.-IZV. RJEŠENJE
vizualizacije

Idejno - izvedbeno rješenje privatnog prostora u Zagrebu
Investitor: Kupac Građanin

M1st design

Dizajner: Matej Kušević

matej.kusevic@m1stdesign.com

+385998218100

m1stdesign.com

svibanj, 2026. godina



ID.-IZV. RJEŠENJE
vizualizacije

Idejno - izvedbeno rješenje privatnog prostora u Zagrebu
Investitor: Kupac Građanin

M1st design

Dizajner: Matej Kušević

matej.kusevic@m1stdesign.com

+385998218100

m1stdesign.com

svibanj, 2026. godina



ID.-IZV. RJEŠENJE
vizualizacije

Idejno - izvedbeno rješenje privatnog prostora u Zagrebu
Investitor: Kupac Građanin

M1st design

Dizajner: Matej Kušević

matej.kusevic@m1stdesign.com

+385998218100

m1stdesign.com

svibanj, 2026. godina



ID.-IZV. RJEŠENJE
vizualizacije

Idejno - izvedbeno rješenje privatnog prostora u Zagrebu
Investitor: Kupac Građanin

M1st design

Dizajner: Matej Kušević

matej.kusevic@m1stdesign.com

+385998218100

m1stdesign.com

svibanj, 2026. godina



ID.-IZV. RJEŠENJE
vizualizacije

Idejno - izvedbeno rješenje privatnog prostora u Zagrebu
Investitor: Kupac Građanin

M1st design

Dizajner: Matej Kušević

matej.kusevic@m1stdesign.com

+385998218100

m1stdesign.com

svibanj, 2026. godina



ID.-IZV. RJEŠENJE
vizualizacije

Idejno - izvedbeno rješenje privatnog prostora u Zagrebu
Investitor: Kupac Građanin

M1st design

Dizajner: Matej Kušević

matej.kusevic@m1stdesign.com

+385998218100

m1stdesign.com

svibanj, 2026. godina



ID.-IZV. RJEŠENJE
vizualizacije

Idejno - izvedbeno rješenje privatnog prostora u Zagrebu
Investitor: Kupac Građanin

M1st design

Dizajner: Matej Kušević

matej.kusevic@m1stdesign.com

+385998218100

m1stdesign.com

svibanj, 2026. godina

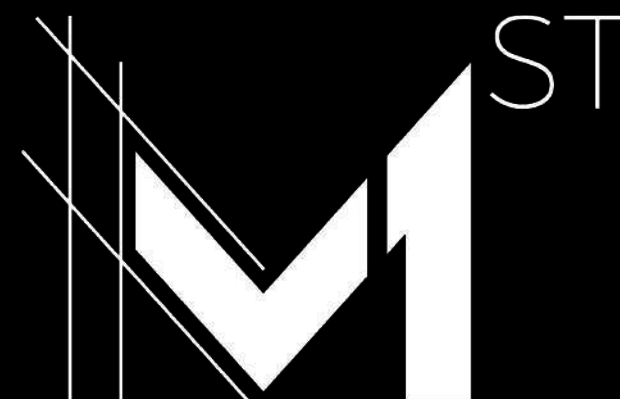

M1ST DESIGN
Studio za dizajn interijera

Hvala Vam!

Idejno - izvedbeno rješenje privatnog prostora
Investitor: kupac građanin

M1st design
Dizajner: Matej Kušević
matej.kusevic@m1stdesign.com
+385998218100
m1stdesign.com
svibanj, 2026. godina